

Lotorq LT SERIES

Full Faced ANSI Flange Gaskets

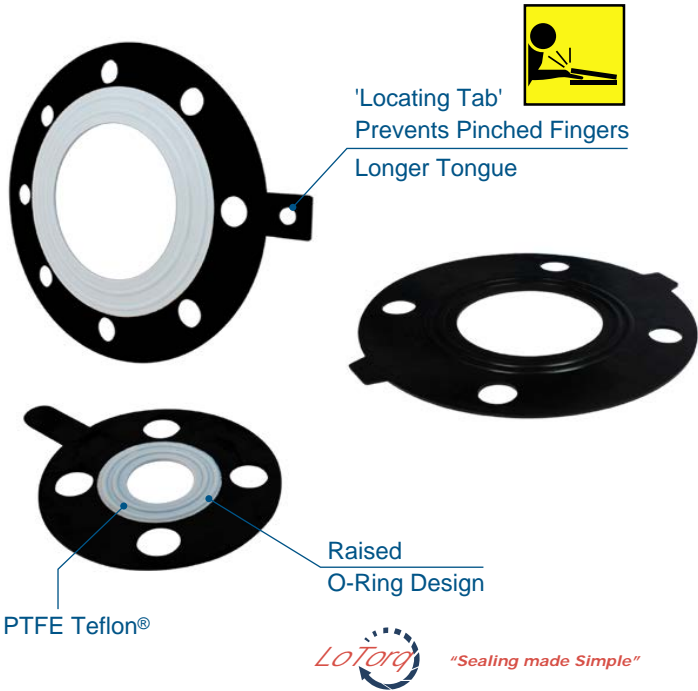

- Reduces Flange Breakage
- Longer Tongue | Prevents Pinched Fingers
- Full Faced | Reduces Pressure Drops



Product Description

The Truflo® Lotorq LT Series Flange Gaskets are recommended for all types of Non-Metal Plastic flanged connections to prevent initial breakage due to bolt over-tightening.

The unique double raised O-Ring Design provides excellent sealing with 75% less bolt torque required for flat face gaskets. The PTFE gaskets have PTFE Teflon® sheet material bonded directly to the EPDM.

The LT Series is ideal for Thermoplastic Piping Systems for applications up to 250 psi.



Dimensions

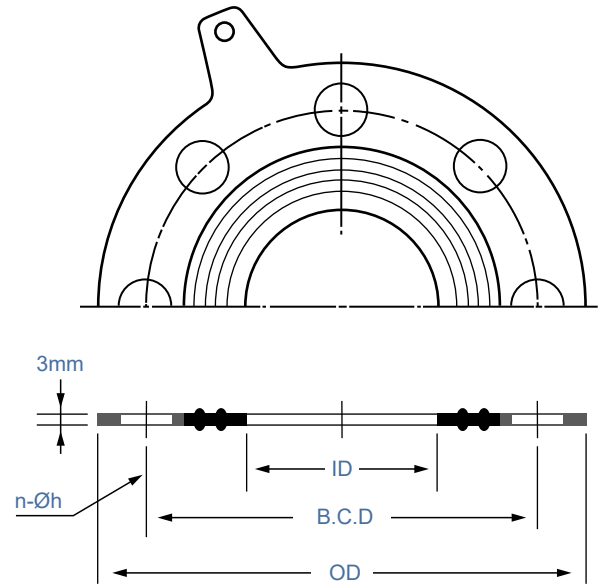

Size	DN	ASME B16.21	ID	OD	B.C.D	No. of Holes	Dia. of Holes
1/2"	15	150#	21	89	60	4	16
3/4"	20	150#	27	98	70	4	16
1"	25	150#	33	108	79	4	16
1-1/2"	40	150#	48	127	98	4	16
2"	50	150#	60	152	121	4	19
2-1/2"	65	150#	73	178	140	4	19
3"	80	150#	89	191	152	4	19
4"	100	150#	114	229	191	8	19
5"	125	150#	141	254	216	8	22
6"	150	150#	168	279	241	8	22
8"	200	150#	219	343	298	8	22
10"	250	150#	273	406	362	12	25
12"	300	150#	324	483	432	12	25
14"	350	150#	356	533	476	12	29
16"	400	150#	406	597	540	16	29
18"	450	150#	457	635	578	16	32
20"	500	150#	508	699	635	20	32
24"	600	150#	610	813	749	20	35

Features

- Double Convex Raised O-Ring Design
- Seals With 75% Less Bolt Torque vs. Flat Faced
- No Over Tightening Required
- Full Faced Design | Reduces Pressure Drop
- Ideal for Thermoplastic Piping Systems
- Location Tab | Eliminates Pinched Fingers