

Thank You

Thanks for purchasing a Recalibratable HU1502I Hammer Union Pressure Transmitter from us! We appreciate your business and your trust. Please take a moment to familiarize yourself with the product and this manual before installation. If you have any questions, at any time, don't hesitate to call us at 888-525-7300.

NOTE: Scan the QR code to the right to see the full user manual on your tablet or smartphone. Or visit www.apgsensors.com/support to find it on our website.



Table of Contents

| | | |
|---------------------------|--------------------------------|--------------------------------|
| 1. Description | 5. Mounting Instructions | 9. Repair & Return Information |
| 2. How To Read Your Label | 6. Wiring Information | 10. Recalibration |
| 3. Warranty | 7. Calibration Shunt Procedure | 11. Removal Instructions |
| 4. Dimensions | 8. General Care | 12. Hazardous Location Wiring |

1 Description

APG's Recalibratable Hammer Union Pressure Transmitters are designed for the environments of land-based and offshore drilling installations. Designed specifically for use with the 1502 Hammer Wing Union, the HU1502I features a NPT-sealed port for digital zero and span recalibration. The HU1502I is constructed from NACE-compliant incoloy for use with sour gases and in corrosive environments.

The HU1502I is certified intrinsically safe for hazardous areas in the US, Canada, Europe and internationally by CSA, ATEX, and IECEx for Class I, Zone 0, and Class II, Division 1, Groups C and D environments.

2 How To Read Your Label

Each label comes with a full model number, a part number, and a serial number. The model number for your Hammer Union Pressure Transmitter will look something like this:

▲ SAMPLE: HU1502I-L24-10K-PSIS-E15-K0

The model number correlates with all the configurable options and tells you exactly what you have. Compare the model number to the options on the datasheet to identify your exact configuration. You can also call us with the model, part, or the serial number and we can help you.

The label also includes the pinout.

3 Warranty

This product is covered by APG's warranty to be free from defects in material and workmanship under normal use and service of the product for 24 months. For a full explanation of our Warranty, please visit <https://www.apgsensors.com/about-us/terms-conditions>. Contact Technical Support to receive a Return Material Authorization before shipping your product back.

Scan the QR code below to read the full explanation of our Warranty on your tablet or smartphone.

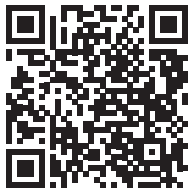

4 Dimensions

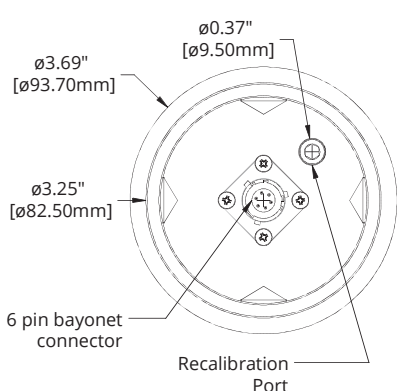

HU1502I

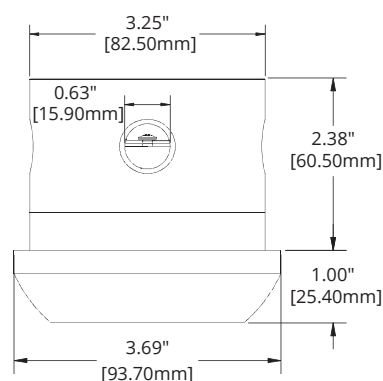

Hammer Union Pressure Transmitters Installation Guide

For The Recalibratable HU1502I



Automation Products Group, Inc.
1025 W 1700 N Logan, UT 84321
www.apgsensors.com | phone: 888-525-7300 | email: sales@apgsensors.com

Doc #9005224 Rev C
Part #200047

5 Mounting Instructions

Mounting your pressure transducer is easy if you follow a few simple steps:

- Ensure mating union faces are clean, dry, and free of debris.
- Place Hammer Union Pressure Transmitter in socket.
- Place Hammer Union wing nut on transmitter and tighten into place.
- Hammer wing nut until tight.

⚠ DANGER: Mismatched unions and nuts can result in dangerous or hazardous equipment failures. Always check identifications on both union pieces and nuts prior to installation. Only use pieces with matching union figure numbers, sizes, and pressure ratings.

ⓘ IMPORTANT: Refer to section 12 for Hazardous Location Wiring.

ⓘ IMPORTANT: Recalibratable HU1502I Hammer Union Pressure Transmitter **MUST** be installed according to drawing 9002460 (Intrinsically Safe Wiring Diagram) to meet listed approvals. Faulty installation will invalidate all safety approvals and ratings.

6 Wiring Information

The label on your Recalibratable HU1502I Pressure Transmitter includes the pinout table for your device. Check that your electrical system wiring matches the pinout table on your device prior to electrical installation.

7 Calibration Shunt Procedure

APG's Hammer Union Pressure Transmitters provide a true 20.0 mA or 5 VDC calibration shunt output when 10 to 28 VDC is applied to the designated + Shunt Cal pin. See the pinout chart on your Hammer Union Pressure Transmitter's label.

8 General Care

Your Recalibratable HU1502I Pressure Transmitter is designed to be maintenance free. As such, there are no customer servicable parts on or in the device. However, in general, you should:

- Avoid touching the diaphragm. Contact with the diaphragm, especially with a tool, could permanently shift the output and ruin accuracy.
- Clean the diaphragm or the diaphragm bore only with extreme care. If using a tool is required, make sure it does not touch the diaphragm.
- See Section 10 Recalibration for recalibration instructions.

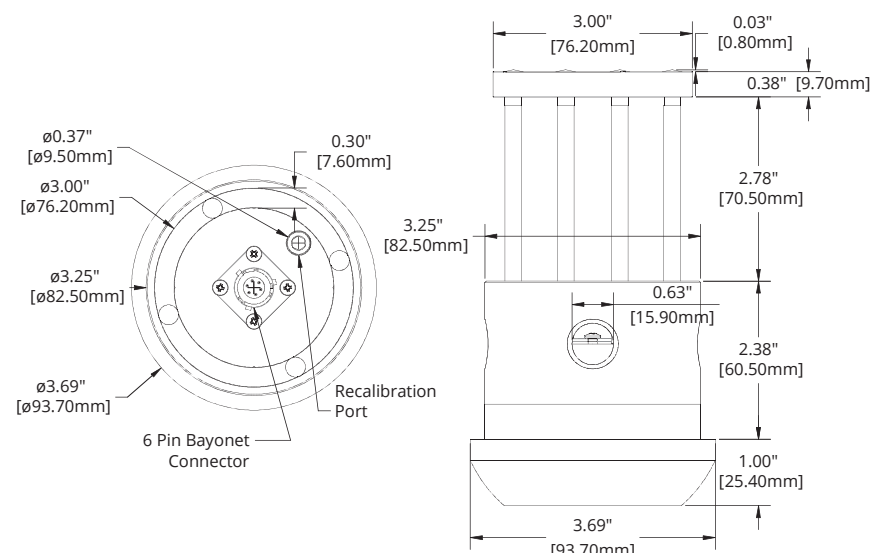

HU1502I with cage

9 Repair & Return Information

If your pressure transmitter needs repair, contact us via email, phone, or online chat on our website. We will issue you an RMA number with instructions.

- Phone: 888-525-7300
- Email: sales@apgsensors.com
- Online chat at www.apgsensors.com

IMPORTANT: All repairs of the Recalibratable HU1502I Pressure Transmitter must be made by the factory. Modifying, disassembling, or altering the Recalibratable HU1502I Pressure Transmitter, other than factory approved recalibration, is strictly prohibited.

10 Recalibration

Please refer to the HU1502I user manual or the HU1502I Recalibration Instruction Guide for full set up and recalibration instructions. A 24 VDC source, an ammeter or voltmeter, and a test station capable of applying full scale pressure to the HU1502I are required for recalibration.

HU1502I User Manual

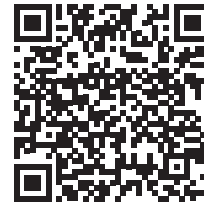

HU1502I Recalibration Instructions



11 Removal Instructions

Removing your Recalibratable HU1502I Pressure Transmitter from service must be done with care. It's easy to create an unsafe situation if you are not careful to follow these guidelines:

- Make sure the pressure is completely removed from the line where your sensor is installed. Follow any and all procedures for safely isolating any media contained inside the line.
- Remove the Hammer Union wing nut.
- Remove your Hammer Union Pressure Transmitter.
- Clean the sensor's fitting and diaphragm of any debris (see instructions in Section 8 above) and inspect for damage.
- Store your sensor in a dry place, at a temperature between -40° F and 180° F.

DANGER: Removing your Hammer Union Pressure Transmitter while there is still pressure in the line could result in injury or death.

12 Hazardous Location Wiring

Intrinsically Safe Wiring (4-20mA / 0-5VDC Output)

| REVISIONS | | | | | |
|-----------|-----|-------------------|---------|-----------|-------------|
| ZONE | REV | DESCRIPTION | CO / EP | DATE | APPROVED |
| -- | D | SEE CHANGE ORDER. | CO-3360 | 7/10/2018 | T. Reidhead |

**INSTALLATION IN CLASS I, DIVISION 1, GROUPS C AND D
INSTALLATION IN CLASS I, ZONE 0, AEx ia IIB T4 Tamb -40° C TO 85° C**

**HAMMER UNION
4-20 mA OUTPUT**

**HAMMER UNION
0-5VDC OUTPUT**

- BARRIERS MUST BE NRTL APPROVED AND MUST BE INSTALLED IN ACCORDANCE WITH MANUFACTURER'S INSTRUCTIONS.
- THIS DEVICE MUST BE CONNECTED TO AN APPROVED SAFETY BARRIER.
- BARRIER PARAMETERS MUST MEET THE FOLLOWING REQUIREMENTS:
 - A. $V_{oc}/U_o \leq V_{max}/U_i$ $C_a/C_o \geq C_i + C_{cable}$
 - B. $I_{sc}/I_o \leq I_{max}/I_i$ $L_a/L_o \geq L_i + L_{cable}$
 - C. $P_o \leq P_i$
- MAXIMUM NON-HAZARDOUS AREA VOLTAGE MUST NOT EXCEED 250V.
- INSTALL IN ACCORDANCE WITH THE NEC (ANSI/NFPA 70) AND ANSI/ISA RP 12.6 (U.S. LOCATIONS) OR CANADIAN ELECTRICAL CODE, PART 1 (CANADIAN LOCATIONS).
- TO MAINTAIN IP67/65 RATING, THE EQUIPMENT SHALL BE INSTALLED WITH A CERTIFIED IP67/65 MATING CONNECTOR.

NON-HAZARDOUS AREA **HAZARDOUS AREA**

V_{max}, U_i = 28VDC
I_{max}, I_i = 110 mA
C_i = 60.89 nF
L_i = 7.7 mH

AGENCY APPROVED DRAWING

DO NOT ALTER WITHOUT PROPER APPROVAL FROM THE CONTROLLING AGENCY AUTHORIZED PERSON AND THE NOTIFIED BODY.

PROPRIETARY AND CONFIDENTIAL
THIS DRAWING IS THE PROPERTY OF AUTOMATION PRODUCTS GROUP, INC. LOGO, DATA AND MAY NOT BE USED, REPRODUCED, PUBLISHED, OR DISCLOSED TO OTHERS WITHOUT WRITTEN CONSENT OF THE COMPANY. IF LOANED, IT IS SUBJECT TO RETURN UPON DEMAND AND MAY NOT BE USED IN ANY WAY DIRECTLY OR INDIRECTLY DERIVATIVE TO THE COMPANY.

| | | |
|---|-----------|-----------|
| UNLESS OTHERWISE SPECIFIED DIMENSIONS ARE IN INCHES AND TO DECIMALS ARE AS FOLLOWS: TO DECIMAL ANGLES: ±1° 2 PLACES: ±0.1 3 PLACES: ±0.005 | APPROVALS | DATE |
| DESIGN: R. O. BOERN | | 4/21/2006 |
| CHECK: E. TOLMAN | | 4/21/2006 |
| APPROVED: M. HARVEY | | 4/21/2006 |
| CONTRACT: | | |
| SCALE: | | |
| PROJ: | | |

APG

AUTOMATION PRODUCTS GROUP, INC.

C SA INTRINSICALLY SAFE HAZARDOUS
INSTALLATION DRAWING HAMMER
UNION PRESSURE TRANSMITTER

1025 West 1700 North
Logan, Utah USA
888.525.7300

REV D

SCALE: 1:1 DO NOT SCALE DRAWING SHEET 1 OF 1