

TIR SERIES

Multi-Function Paddle Wheel Flow Meter



Quick Start

TIR Series Flow Meters

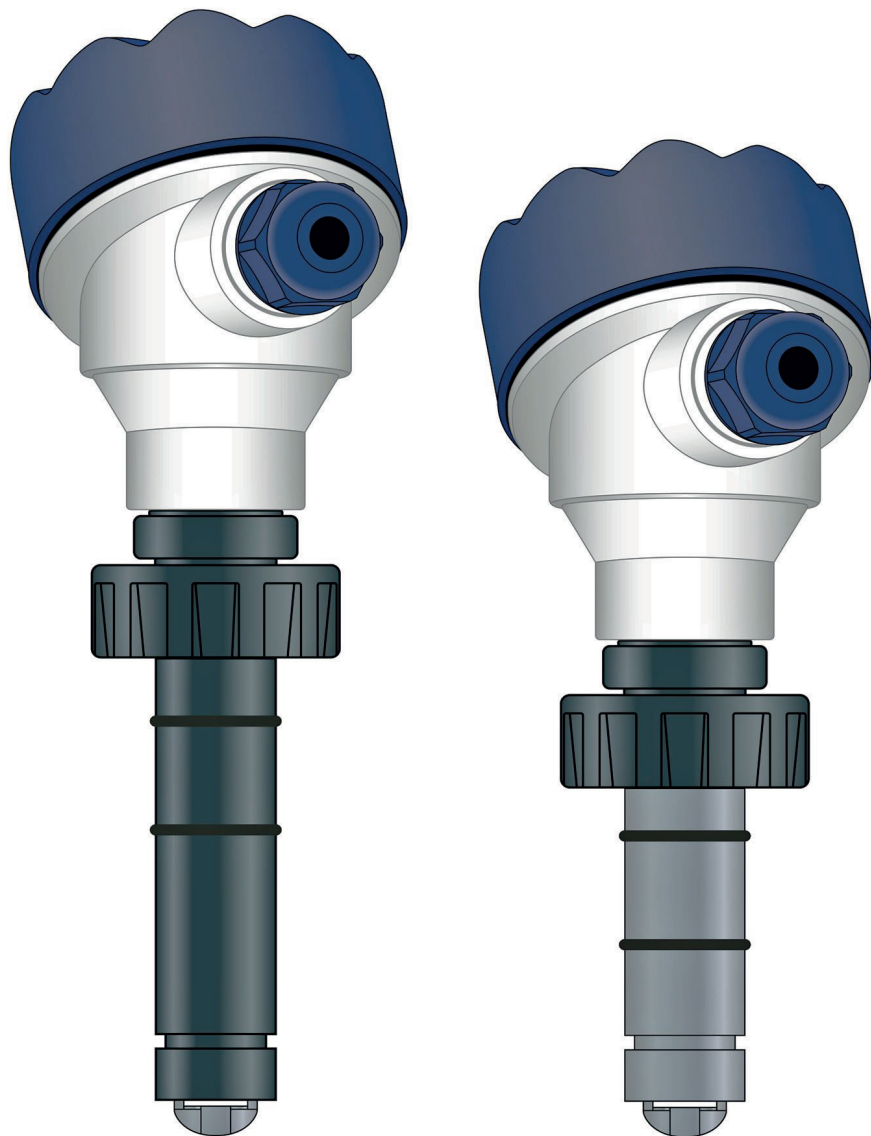

Corrosion-Free
Instrumentation Equipment

Safety Information

1. De-pressurize and Vent System Prior to Installation or Removal.
2. Confirm Chemical Compatibility Before Use.
3. DO NOT Exceed Maximum Temperature or Pressure Specifications.
4. ALWAYS Wear Safety Goggles or Face-Shield During Installation and/or Service.
5. DO NOT Alter Product Construction.



Warning | Caution | Danger

Indicates a potential hazard. Failure to follow all warnings may lead to equipment damage, injury, or death



Hand Tighten Only

Overtightening may permanently damage product threads and lead to failure of the retaining nut.



Note | Technical Notes

Highlights additional information or detailed procedure.



Do Not Use Tools

Use of tool(s) may damage product beyond repair and potentially void product warranty.



WARNING!

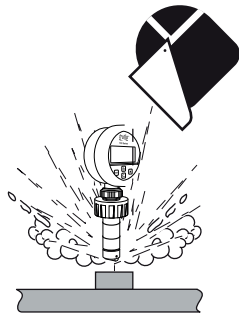

Personal Protective Equipment (PPE)

Always utilize the most appropriate PPE during installation and service of Truflo products.



Pressurized System Warning

Sensor may be under pressure, take caution to vent system prior to installation or removal. Failure to do so may result in equipment damage and/or serious injury.

General Information

Specification	Description
Operating Voltage	10 - 30VDC
Current Consumption	60mA max.
Control Output	RS-485 Modbus
Transmitter	4-20mA
Relay Output	1A 30VDC Normally Open Normally Closed
Flow Rate GPM LPM	0.0 - 999.9
Fluid	H ₂ O Liquid Chemical Media
Accuracy	± 0.5% of F.S. @ 25°C
Response Frequency	5K Hz
Max Flow Rate	10m/s 33ft/s
Min Flow Rate	0.1m/s 0.3ft/s
Materials of Construction	Rotor ETFE Tefzel® Rotor Pin Zirconium Ceramic Rotor Bushings Ceramic Sensor Body PVC PP PVDF 316SS
O-Ring Material	FPM EPDM Optional FFKM Optional
Operating Temperature	PVC < 60°C PP < 80°C PF < 100°C
Protection Class	NEMA 4X IP66 General Purpose
Approval	CE RoHS

*Optional

Installation



Very Important

- ❑ Lubricate O-rings with a Viscous Lubricant Compatible with the Materials of Construction.
- ❑ Using an Alternating | Twisting Motion Carefully Lower the Sensor into the Fitting. | Do Not Force | Fig 5
- ❑ Ensure Tab | Notch are Parallel to Flow Direction | Fig-2



Hand Tighten the Sensor Cap. **DO NOT** use any tools on the sensor cap or the cap threads or fitting threads may be damaged. | Fig-5

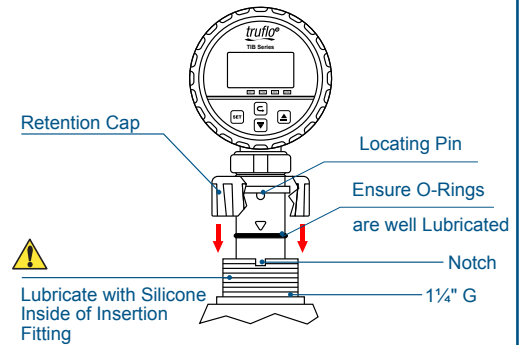

Fig-3

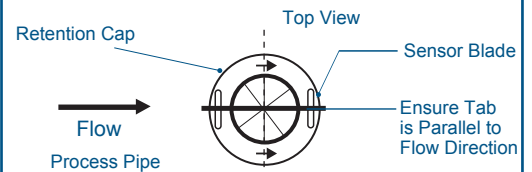

Fig-4

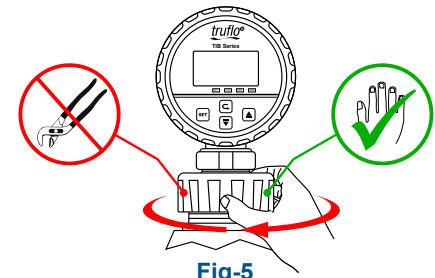
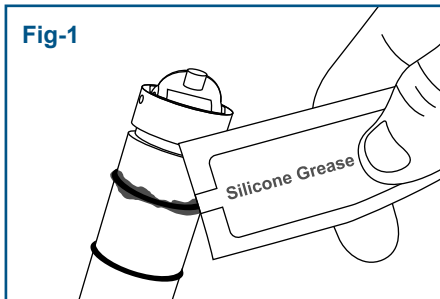

Fig-5

Fig-1



Ensure the Silicon Grease Provided is Applied Prior to Insertion

Fig-2

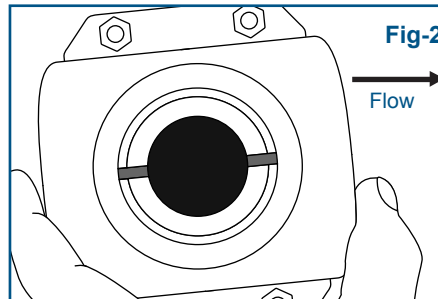

Ensure Location Tabs Are Parallel to Direction of Flow

Correction Sensor Position

01

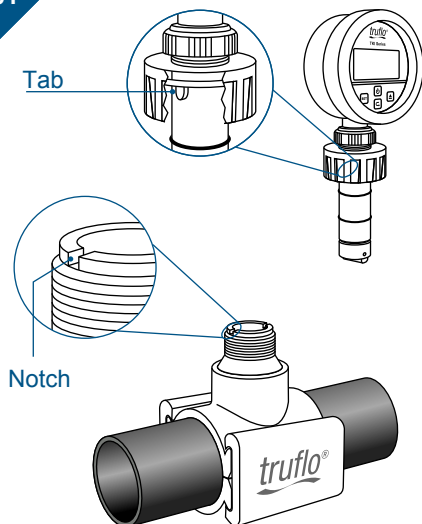

Flow Meter Positioning Tab and Clamp Saddle Notch

02

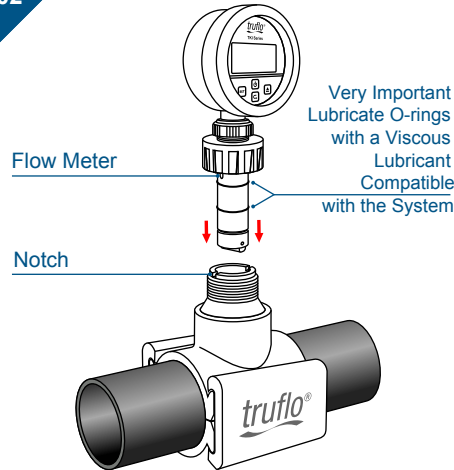

Engage one Thread of the Sensor Cap then turn the Sensor until the Alignment Tab is Seated in the Fitting Notch, Ensure Tab is Parallel to Flow Direction.

03

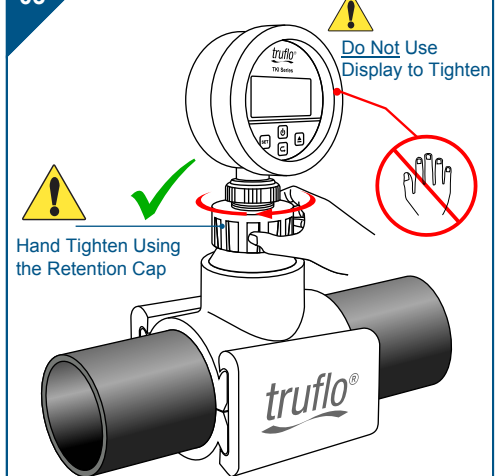

- Hand Tighten the Screw Cap.
- **DO NOT** use any Tools, Threads may be Damaged.
- Ensure Meter is Firmly in Place

TIR SERIES

Multi-Function Paddle Wheel Flow Meter



Terminal Connections

- With Transmitter or RS-485

Power		Tr RS		Output		
1	2	3	4	5	6	7
+V	0V	-	+	COM	NO	NC

Power | 10-30VDC
 Tr | 4-20mA
 RS | RS-485 Modbus
 Output | Relay 1A | 30VDC

Power		Tr RS		Output		
1	2	3	4	5	6	7
+V	-V	-	+	COM	NO	NC

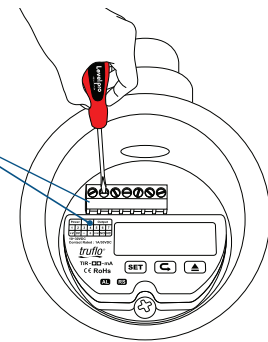

Wiring Procedure

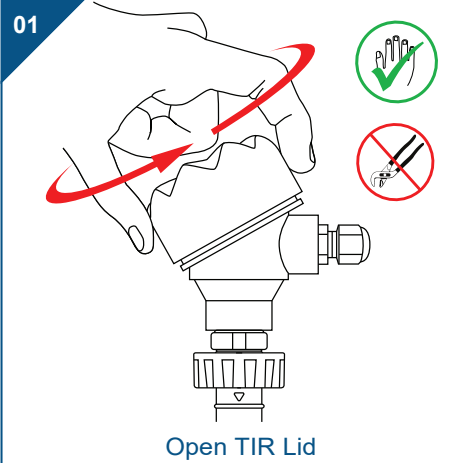

Open TIR Lid

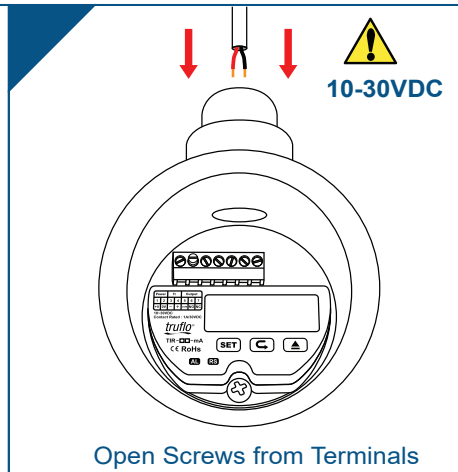

Open Screws from Terminals

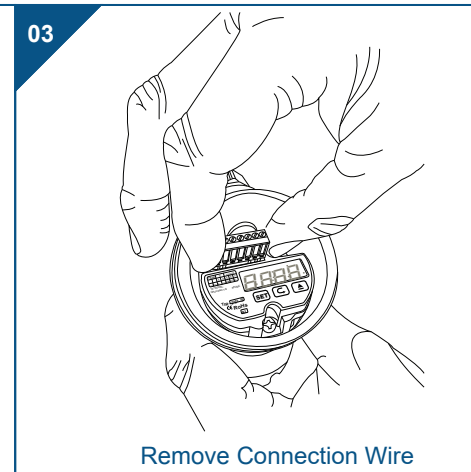

Remove Connection Wire

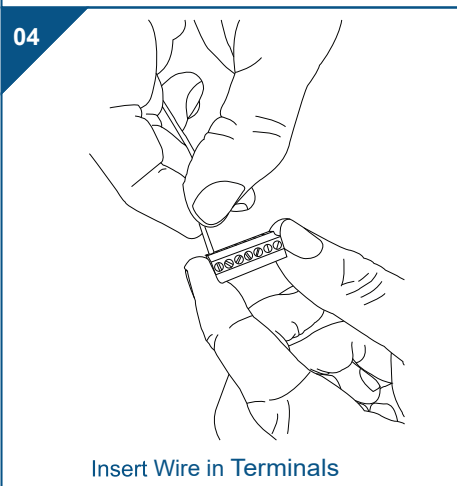

Insert Wire in Terminals

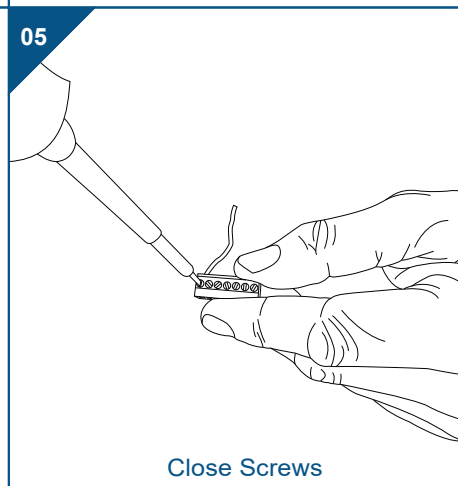

Close Screws

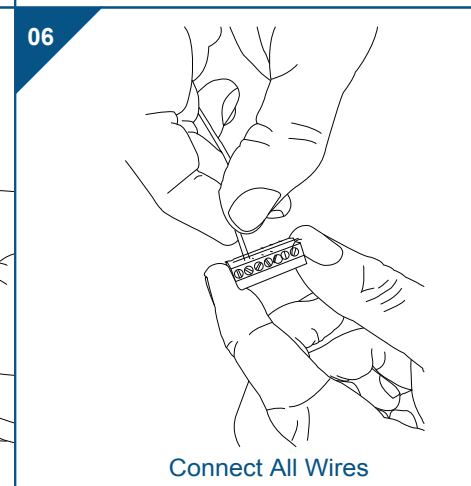

Connect All Wires

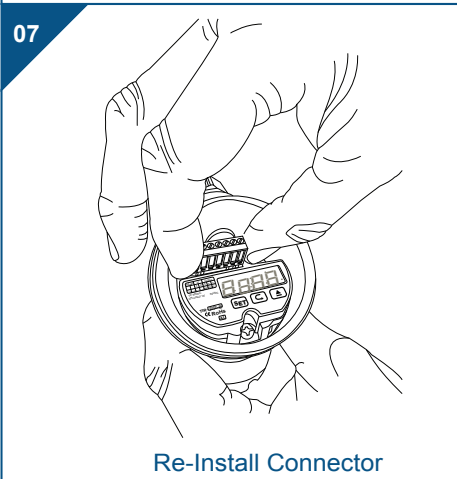

Re-Install Connector

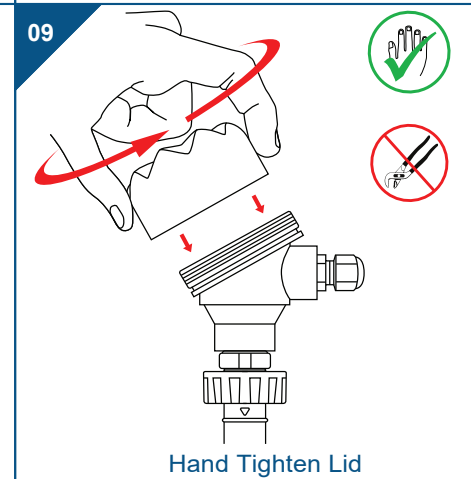
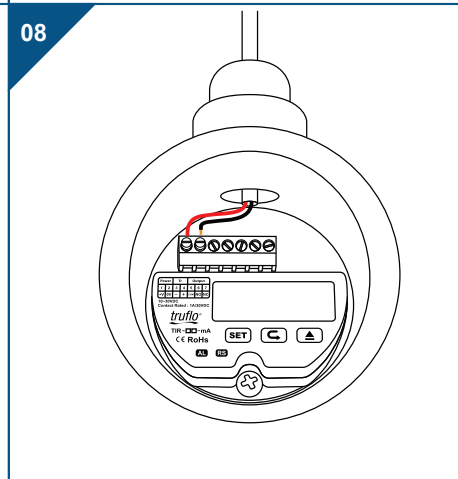

Hand Tighten Lid

Correction Sensor Position

TI Series Flow Meters measure liquid media only. There should be no air bubbles and the pipe must always remain full. To ensure accurate flow measurement the placement of the flow meters needs to be adhered. This requires a straight run pipe with a minimum number of pipe diameters distance upstream and downstream of the flow sensor.

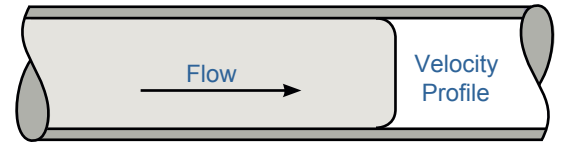

Developed Turbulent Flow



Flange

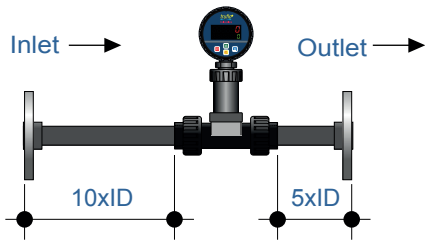

2x 90 Elbow

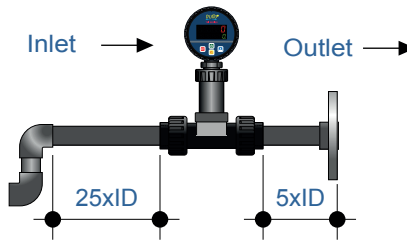

Reducer

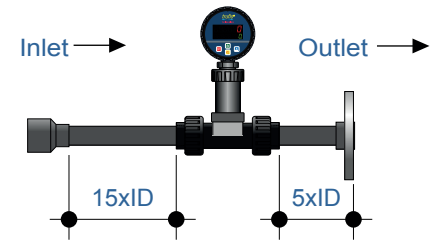

90 Elbow Downward flow

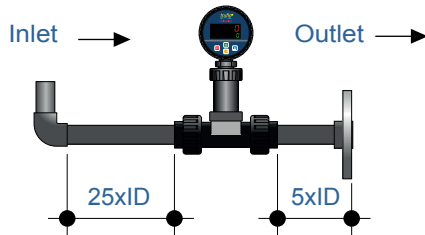

90 Elbow Downward flow Upward

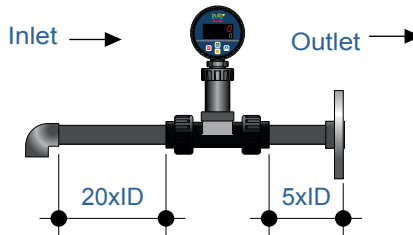

Ball Valve

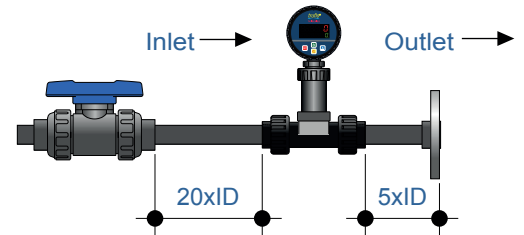

Installation Positions

Figure 1

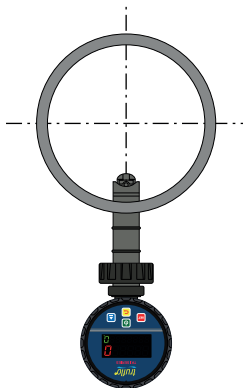

Good if NO Sediment Present

Figure 2

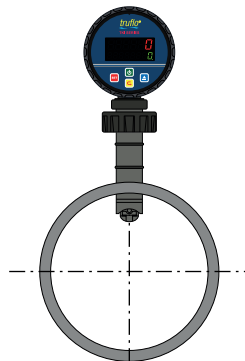

Good if NO Air Bubbles Present

Figure 3

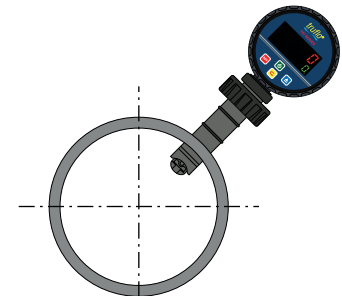

Preferred Installation if Sediment* or Air Bubbles may be Present

* Maximum % Solids: 10% with particle size not exceeding 0.5 mm cross section or length.

CORROSION



Do Not Use Display to Tighten

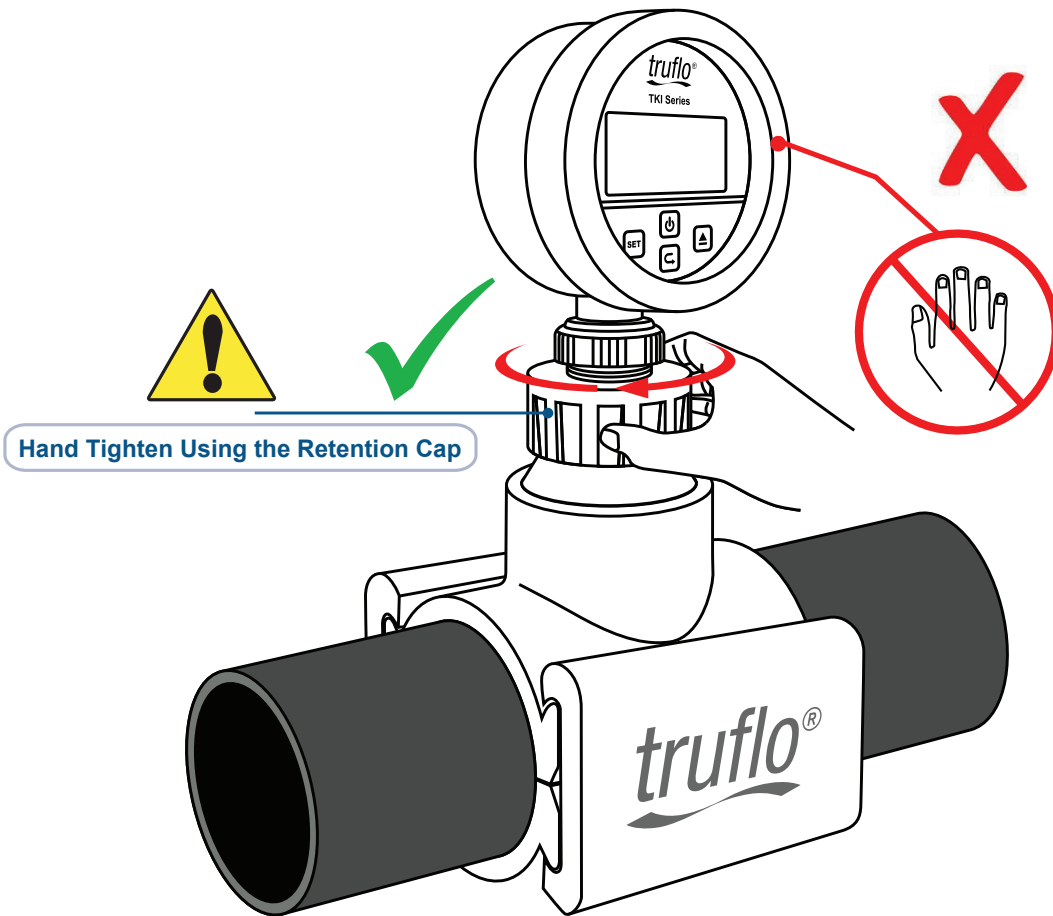

Hand Tighten Using the Retention Cap

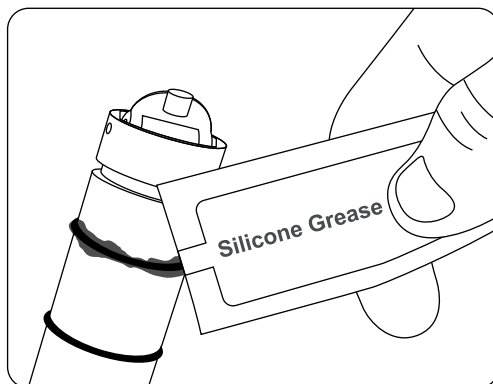

Ensure Silicone Grease* is Applied to O-Rings Prior to Insertion into Fitting

*Ensure Silicone Grease is Suitable for Application

Long Service Life

The TIR Series is equipped with a Zirconium Ceramic Rotor Pin and 2 Bushings. The TIR Series also incorporates a contoured, 'Low Drag' Paddle Wheel leading to reduced drag, longer wear and higher accuracy.

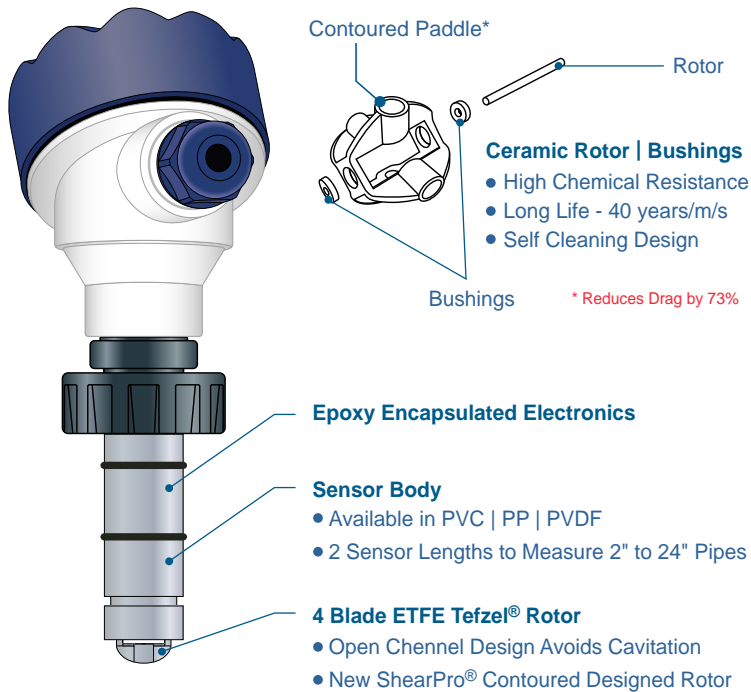

Pressure vs. Temperature

Note : During system design the specifications of all components must be considered. | Non-Shock

■ = PVC ■ = PP ■ = PVDF

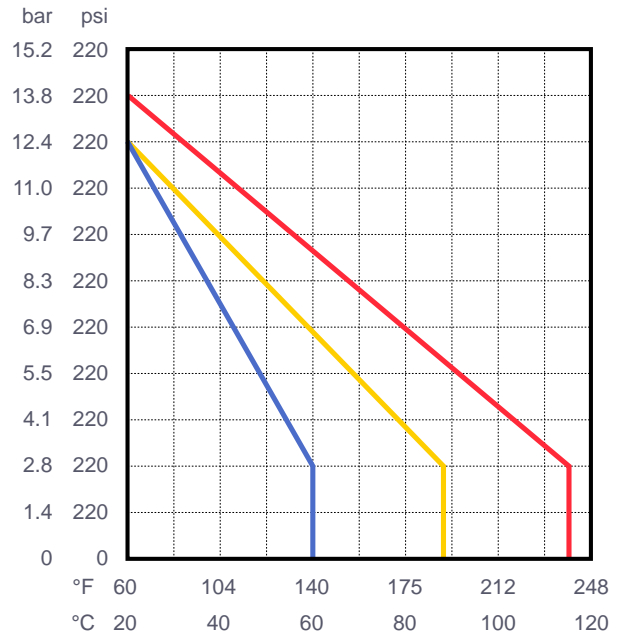

Min | Max Flow Rates

Pipe Size (O.D.)	LPM GPM	LPM GPM
	0.3m/s min.	10m/s max.
2" DN50	40.0 10.5	357.0 1350.0
2 ½" DN60	60.0 16.0	1850 357
3" DN80	90.0 24.0	2800 739
4" DN100	125.0 33.0	4350 1149
6" DN150	230.0 60.0	7590 1997
8" DN200	315.0 80.0	10395 2735

Dimensions

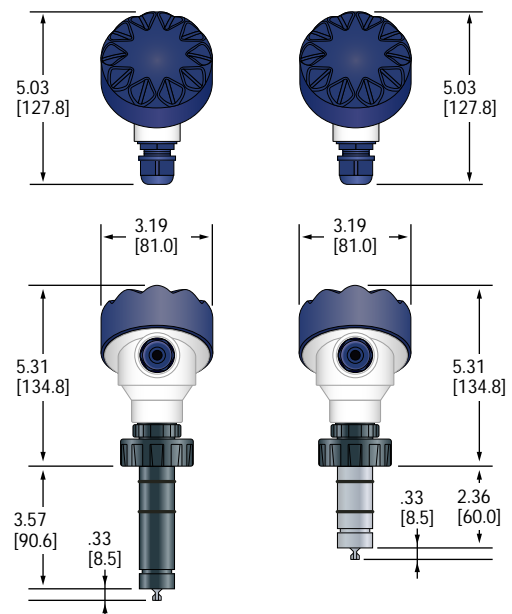

Wiring Diagram

With Transmitter or RS-485

Power		Tr RS		Output		
1	2	3	4	5	6	7
+V	0V	-	+	COM	NO	NC

Power = 10-30VDC
 Tr = 4 ~ 20mA
 RS = RS-485 (Modbus)
 Output = Relay (1A/30VDC)

Programming

	Display	Range	Description
Home Screen Press SET 3 Secs	00	0 - 999.9	Home Screen
K Factor Press SET	2		K Factor
K Factor Press SET	9999	0.1 - 99.99	Enter K Factor Value Refer to Chart on Page 7
Transmitter Range Press SET	Er		4-20mA Output Range
Transmitter Range Press SET	1000	0-999.9	4mA = 0 Factory Default = No Flow 20mA = 100 Default** **This can be Changed to Conform to Customers Application
Alarm Press SET	AL		Alarm Relay
Alarm Set Point Press SET	1000	0-999.9	Alarm Set Point
Hysteresis Press SET	HYS		Alarm Hysteresis } Prevents Relay Chatter
Hysteresis Press SET	10	0-999.9	Enter Hysteresis Value

Programming Alarm

Status	Display	Range	Description
Home Screen Press SET + ESC 3 Secs	00	0 - 999.9	Home Screen
Lock Out Feature Press SET	Lk. 10	1 - 10	Factory Default: Lock = 10 NOTE: If Lock # is Changed from the # 10 the Meter will enter the Lockout Mode.
Decimal Place Press SET	dP. 1	0 or 1	Change Decimal Place
Units of Flow Press SET	Ut. 6		Ut.6 = Gallons Factory Default Ut.L = Liters Ut.KL = Kiloliters
Programming Relay Press SET	ALt. 0	0 - 4	Alt = 0 Factory Default = No Relay Refer to Relay Selection Mode on Next Page
Relay Time Delay Press SET	t.00	0 - 99S	Start Up Delay Time in Seconds Prevents False Alarms during Start-Ups

TIR SERIES

Multi-Function Paddle Wheel Flow Meter



Alarm Settings

Mode	Description	
ALt.0	No Alarm	
ALt.1		
	CV > (AL1) → R1/AL1 ON ; C →	CV > (AL2) → R2/AL2 ON ; CV > (AL2+H) → R2/AL2 OFF
ALt.2		
	CV < (AL1 - H) → AL1 → R1/AL1	CV > (AL2 + H) → R2/AL2 ON ; CV < AL2 → R2/AL2 OFF
ALt.3		
	CV > AL1 → R1/AL1 OFF ; CV < (AL1 - →	CV > AL2 → R2/AL2 OFF ; < (AL2 - H) → R
ALt.4		
	CV > (AL1) → R1/AL1 ON ; C →	CV > AL2 → R2/AL2 ON ; CV < (AL2 - H) → R2/AL2 OFF

Fittings

TEE FITTINGS					CLAMP-ON SADDLES					CPVC SOCKET WELD-ON ADAPTERS							
Tee Fitting Size	IN	DN	K-Factor LPM	K-Factor GPM	Sensor Length	Clamp Saddles Size	IN	DN	K-Factor LPM	K-Factor GPM	Sensor Length	Weld On Adapter Size	IN	DN	K-Factor LPM	K-Factor GPM	Sensor Length
1/2"		50	268.0	1013.0	S	2"		50	21.6	81.7	S	2"		50	14.4	54.4	S
3/4"		50	160.0	604.0	S	3"		80	9.3	35.0	S	2-1/2"		65	9.3	35.5	S
1"		50	108.0	408.0	S	4"		100	5.2	19.8	S	3"		80	9.3	35.0	S
1-1/2"		50	37.0	140.0	S	6"		150	2.4	9.2	L	4"		100	5.2	19.8	S
2"		50	21.6	81.7	L	8"		200	1.4	5.2	L	6"		150	2.4	9.2	L
2-1/2"		65	14.4	54.4	L							8"		200	1.4	5.2	L
3"		80	9.3	35.0	L							10"		250	0.91	3.4	L
4"		100	5.2	19.8	L							12"		300	0.65	2.5	L
												14"		50	0.5	1.8	L
												16"		65	0.4	1.4	L
												18"		80	0.3	1.1	L
												20"		100	0.23	0.9	L
												24"		150	0.16	0.6	L

Rotor Pin | Paddle Replacement

<p>01</p> <p>Line up Pin with Rotor Hole</p> <p>Small Pin</p> <p>Rotor Hole</p>	<p>02</p> <p>GENTLY tap pin with Mallet or Hammer</p>	<p>03</p> <p>Tap until Rotor is 50% out</p>
<p>04</p> <p>Pull out Rotor Pin</p>	<p>05</p> <p>Paddle</p> <p>Pull Out Rotor Pin entire way until Paddle Wheel is loose</p>	<p>06</p> <p>Insert New Paddle in Flow Meter</p>
<p>07</p> <p>Push in Rotor Pin approx. 50%</p>	<p>08</p> <p>GENTLY tap Rotor Pin with Mallet or Hammer</p> <p>Ensure Holes are Aligned</p>	<p>09</p> <p>Congratulations! Replacement Procedure Complete!</p>

Warranty, Returns and Limitations

Warranty

Icon Process Controls Ltd warrants to the original purchaser of its products that such products will be free from defects in material and workmanship under normal use and service in accordance with instructions furnished by **Icon Process Controls Ltd** for a period of one year from the date of sale of such products. **Icon Process Controls Ltd** obligation under this warranty is solely and exclusively limited to the repair or replacement, at **Icon Process Controls Ltd** option, of the products or components, which **Icon Process Controls Ltd** examination determines to its satisfaction to be defective in material or workmanship within the warranty period. **Icon Process Controls Ltd** must be notified pursuant to the instructions below of any claim under this warranty within thirty (30) days of any claimed lack of conformity of the product. Any product repaired under this warranty will be warranted only for the remainder of the original warranty period. Any product provided as a replacement under this warranty will be warranted for the one year from the date of replacement.

Returns

Products cannot be returned to **Icon Process Controls Ltd** without prior authorization. To return a product that is thought to be defective, go to www.iconprocon.com, and submit a customer return (MRA) request form and follow the instructions therein. All warranty and non-warranty product returns to **Icon Process Controls Ltd** must be shipped prepaid and insured. **Icon Process Controls Ltd** will not be responsible for any products lost or damaged in shipment.

Limitations

This warranty does not apply to products which: 1) are beyond the warranty period or are products for which the original purchaser does not follow the warranty procedures outlined above; 2) have been subjected to electrical, mechanical or chemical damage due to improper, accidental or negligent use; 3) have been modified or altered; 4) anyone other than service personnel authorized by **Icon Process Controls Ltd** have attempted to repair; 5) have been involved in accidents or natural disasters; or 6) are damaged during return shipment to **Icon Process Controls Ltd** reserves the right to unilaterally waive this warranty and dispose of any product returned to **Icon Process Controls Ltd** where: 1) there is evidence of a potentially hazardous material present with the product; or 2) the product has remained unclaimed at **Icon Process Controls Ltd** for more than 30 days after **Icon Process Controls Ltd** has dutifully requested disposition. This warranty contains the sole express warranty made by **Icon Process Controls Ltd** in connection with its products. **ALL IMPLIED WARRANTIES, INCLUDING WITHOUT LIMITATION, THE WARRANTIES OF MERCHANTABILITY AND FITNESS FOR A PARTICULAR PURPOSE, ARE EXPRESSLY DISCLAIMED.** The remedies of repair or replacement as stated above are the exclusive remedies for the breach of this warranty. **IN NO EVENT SHALL Icon Process Controls Ltd BE LIABLE FOR ANY INCIDENTAL OR CONSEQUENTIAL DAMAGES OF ANY KIND INCLUDING PERSONAL OR REAL PROPERTY OR FOR INJURY TO ANY PERSON. THIS WARRANTY CONSTITUTES THE FINAL, COMPLETE AND EXCLUSIVE STATEMENT OF WARRANTY TERMS AND NO PERSON IS AUTHORIZED TO MAKE ANY OTHER WARRANTIES OR REPRESENTATIONS ON BEHALF OF Icon Process Controls Ltd.** This warranty will be interpreted pursuant to the laws of the province of Ontario, Canada.

If any portion of this warranty is held to be invalid or unenforceable for any reason, such finding will not invalidate any other provision of this warranty.

For additional product documentation and technical support visit www.iconprocon.com | e-mail: sales@iconprocon.com support@iconprocon.com | Ph: 905.469.9283

CORROSION

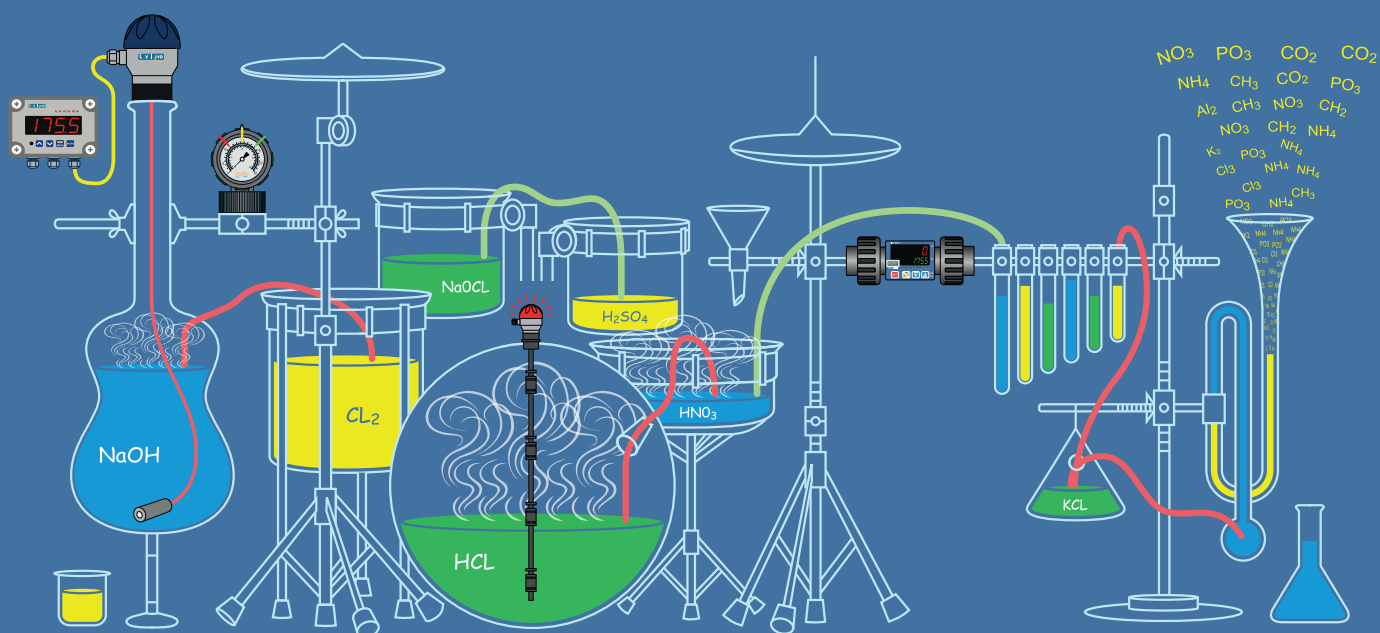

We Measure & Control
All Kinds of Corrosive Liquid S#*o/a

*Industry's Most Extensive Line of
Corrosion-Free Instrumentation Equipment*



Corrosion-Free
Instrumentation Equipment