

## Thank You

Thanks for purchasing a PT-400 series pressure transmitter from us! We appreciate your business and your trust. Please take a moment to familiarize yourself with the product and this manual before installation. If you have any questions, at any time, don't hesitate to call us at 888-525-7300.

NOTE: Scan the QR code to the right to see the full user manual on your tablet or smartphone. Or visit [www.apgsensors.com/support](http://www.apgsensors.com/support) to find it on our website.



## Table of Contents

1. Description	5. Mounting Instructions	9. General Care
2. How To Read Your Label	6. Wiring Information	10. Repair Information
3. Warranty	7. Zero Trimming	11. Disassembly Instructions
4. Dimensions	8. Re-calibration	12. Hazardous Location Wiring

## 1 Description

The PT-400 series pressure transmitter offers reliability over a wide range of pressures and in harsh industrial conditions and hazardous locations. It is certified intrinsically safe for hazardous areas in the US, Canada, Europe and internationally by CSA, ATEX, and IECEx for Class 1, Zone 0 environments.

## 2 How To Read Your Label

Each label comes with a full model number, a part number, and a serial number. The model number for the PT-400 will look something like this:

▲ SAMPLE: PT-400-L1-100-PSI-G-E5-5-P5-N0-M1-S0

The model number correlates with all the configurable options and tells you exactly what you have. Compare the model number to the options on the datasheet to identify your exact configuration. You can also call us with the model, part, or the serial number, and we can help you.

The label also includes the pinout, as does this installation guide.

You'll also find all hazardous certification information on the label.

## 3 Warranty

This product is covered by APG's warranty to be free from defects in material and workmanship under normal use and service of the product for 24 months. For a full explanation of our Warranty, please visit <https://www.apgsensors.com/about-us/terms-conditions>. Contact Technical Support to receive a Return Material Authorization before shipping your product back.

Scan the QR code below to read the full explanation of our Warranty on your tablet or smartphone.



## 4 Dimensions

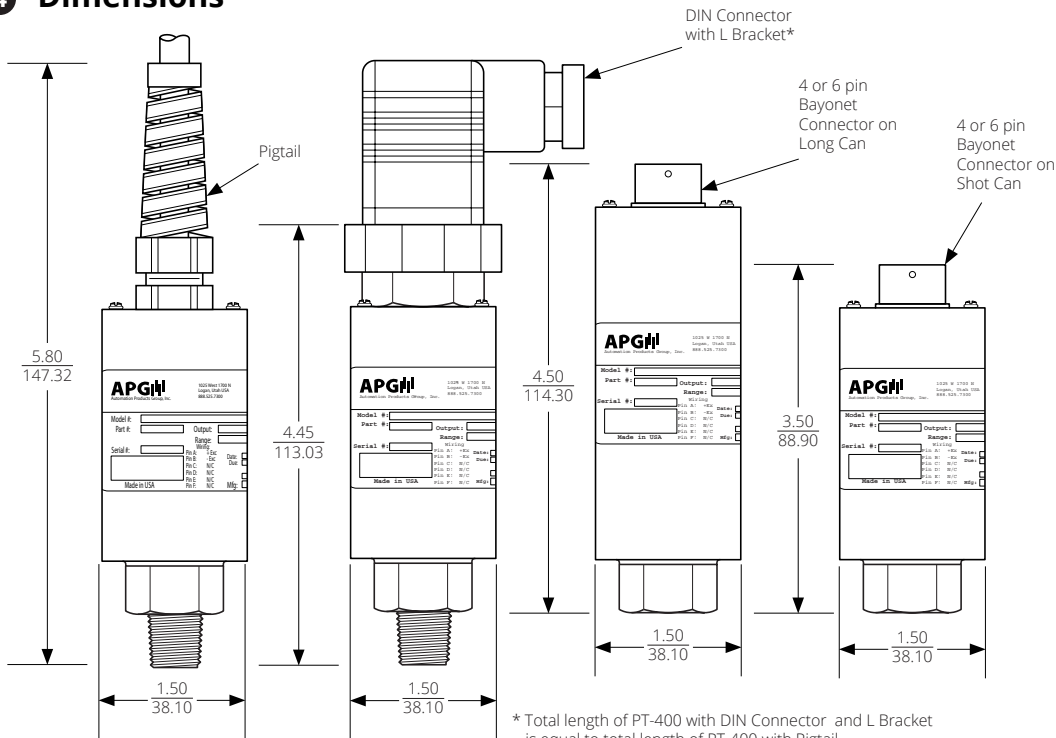

# PT-400 Series Pressure Transmitters

## Installation Guide

### For The PT-400



Automation Products Group, Inc.  
1025 W 1700 N Logan, UT 84321  
[www.apgsensors.com](http://www.apgsensors.com) | phone: 888-525-7300 | email: [sales@apgsensors.com](mailto:sales@apgsensors.com)

Part # 122950-0001  
Doc #9004026 Rev D

## 5 Mounting Instructions

The PT-400 should be installed in an area--indoors or outdoors--which meets the following conditions:

- Ambient temperature between -40°F and 185°F (-40°C to 85°C)
- Relative humidity up to 100%
- Altitude up to 2000 meters (6560 feet)
- IEC-664-1 Conductive Pollution Degree 1 or 2
- IEC 61010-1 Measurement Category II
- No chemical corrosive to stainless steel (such as NH<sub>3</sub>, SO<sub>2</sub>, Cl<sub>2</sub>, etc.)
- Ample space for maintenance and inspection
- Class II power supply

Mounting your pressure transducer is easy if you follow a few simple steps:

- Ensure that the fitting on your sensor matches the fitting on your tank/vessel/pipe/etc. If the fittings do not match, do not attempt to install the sensor. Contact the factory immediately.
- Never over-tighten the sensor. This can compress the diaphragm, changing how it reacts to pressure. In all cases, tighten the sensor as little as possible to create an adequate seal. On straight threads, tighten only until you feel the o-ring compress - making sure you don't damage or extrude the o-ring.
- Always use thread tape or sealant compound on tapered threads. Straight threads use an o-ring. If using thread tape, wrap the tape in the opposite direction of the threads so it does not unravel as you screw it into place. Unraveling can cause uneven distribution and seal failure.
- Always start screwing in your sensor by hand to avoid cross-threading. Thread failure can be a problem if you damage threads by over-tightening them or by crossing threads.

## 6 Wiring Information

PT-400 Series Pin Out Table

		4-20 mA	0-5 / 0.5-4.5 / 1-5 VDC	0-10 VDC	RS-485
 6 Pin Bayonet	A	+ Excitation	+ Excitation	+ Excitation	+ Excitation
	B	- Excitation	+ Output	+ Output	- Excitation
	C	N/C	- Output	- Output	N/C
	D	N/C	- Excitation	- Excitation	B (Tx-)
	E	N/C	N/C	N/C	A (Tx+)
	F	N/C	N/C	N/C	Case GND
 4 Pin Bayonet	A	+ Excitation	+ Excitation	+ Excitation	N/A
	B	- Excitation	+ Output	+ Output	N/A
	C	N/C	- Output	- Output	N/A
	D	N/C	- Excitation	- Excitation	N/A
 4 Pin DIN	1	+ Excitation	+ Excitation	+ Excitation	+ Excitation
	2	- Excitation	+ Output	+ Output	A (Tx+)
	3	N/C	- Output	- Output	B (Tx-)
	4	Case GND	- Excitation	- Excitation	- Excitation
 4 Pin M12	1	+ Excitation	+ Excitation	+ Excitation	+ Excitation
	2	- Excitation	+ Output	+ Output	A (Tx+)
	3	N/C	- Output	- Output	- Excitation
	4	N/C	- Excitation	- Excitation	B (Tx-)
Cable	Red	+ Excitation	+ Excitation	+ Excitation	+ Excitation
	Grn	N/C	+ Output	+ Output	B (Tx-)
	Wht	N/C	- Output	- Output	A (Tx+)
	Blk	- Excitation	- Excitation	- Excitation	- Excitation
	Shld	Gnd	Gnd	Gnd	Gnd

N/C indicates no connection  
For alternate pinouts, please consult factory

PT-400 Series Supply Power Table

	4-20 mA	0-5 / 0.5-4.5 / 1-5 VDC	0-10 VDC	RS-485
Power Supply	9-28 VDC	9-28 VDC	12.5-28 VDC	9-28 VDC

IMPORTANT: Refer to section 12 for Hazardous Location Wiring.

IMPORTANT: PT-400 Modbus sensors use reversed Tx+/Tx- pins. When connecting to your system, ensure continuity of Tx- to Tx- and Tx+ to Tx+, rather than A to A and B to B.

## 7 Zero Trimming

- Remove protective screw(s) with 5/64 allen wrench.
- Ensure that the transducer is at 0 psig or 0 psia (vacuum if absolute).
- Using a jeweler's screwdriver or a suitable instrument, adjust the "Z" pot until you have a 4 mA, 0 V, 0.5 V, or 1 V output.
- Replace protective screw(s) when finished.

**NOTE:** You may also return the transducer to the factory for repair and/or adjustment.

**IMPORTANT:** Do not make changes to the Span adjustment (the "S" pot to the right, see Figure 7.1) as part of the zero trimming. The Span should only be changed as part of the recalibration of a gauge with a known pressure source.

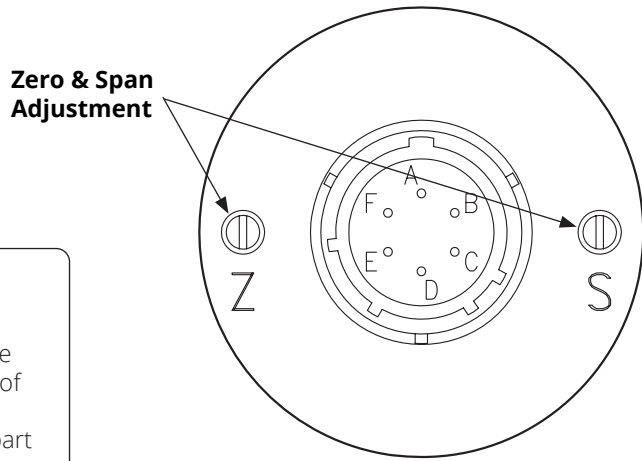

Figure 7.1

**DANGER:** Protective screws must be replaced using 28 oz-in of torque to create seal.

## 8 Re-Calibration

This procedure requires a known pressure source of at least  $\pm 0.1\%$  accuracy in order to fully utilize the accuracy potential of the transducer. (If not available, you can return it to the factory for re-calibration.)

- Ensure that the transducer is at 0 psig or 0 psia (vacuum if absolute), and adjust zero as per instructions for zero trimming.
- Apply full scale pressure to the pressure port and adjust the Span ("S") pot (on the right of Figure 7.1) until the full scale signal is reached.
- Re-check zero and re-adjust the zero ("Z") pot if required
- Repeat previous two steps until no further adjustment is required.

**NOTE:** You may also return the transducer to the factory for repair and/or adjustment.

## 12 Hazardous Location Wiring

### Intrinsically Safe Wiring (4-20mA Output)

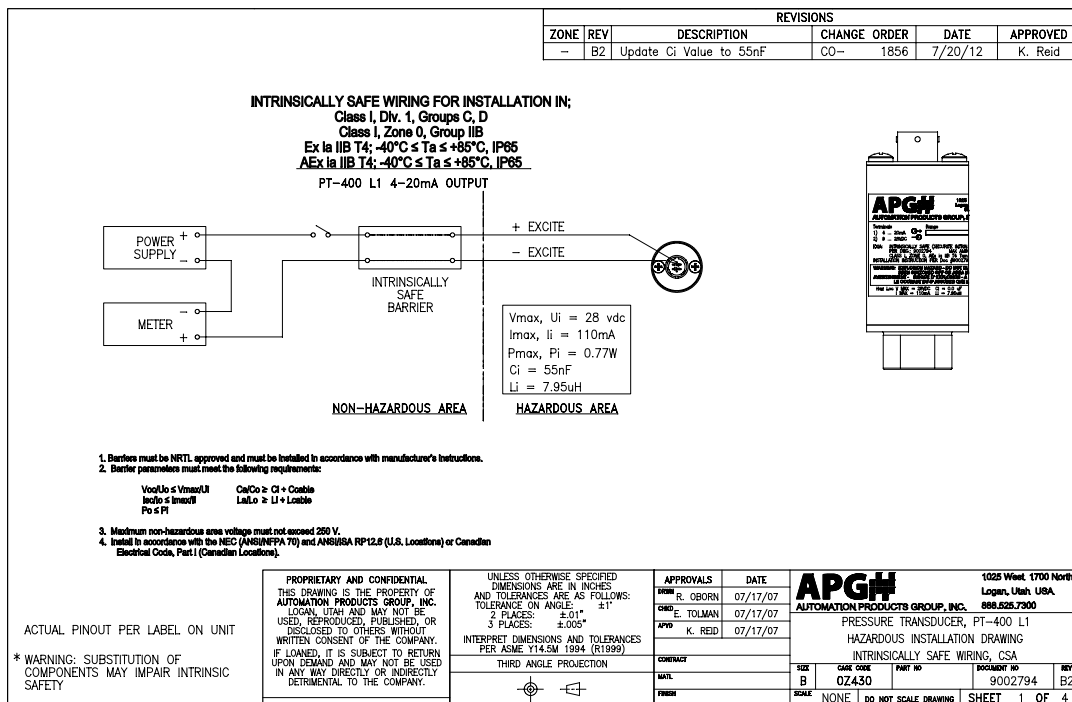

## 9 General Care

Your pressure transmitter is very low maintenance and will need little care, as long as it was installed correctly. However, in general, you should:

- Keep the sensor and the area around it generally clean.
- Avoid applications for which the sensor was not designed, such as extreme temperatures, contact with incompatible corrosive chemicals, or other damaging environments.
- Inspect the threads whenever you remove the sensor from duty or change its location.
- Avoid touching the diaphragm. Contact with the diaphragm, especially with a tool, could permanently shift the output and ruin accuracy.
- Cleaning the diaphragm or the diaphragm bore should be done with extreme care. If using a tool is required, make sure it does not touch the diaphragm.

## 10 Repair Information

If your pressure transmitter needs repair, contact us via email, phone, or online chat on our website. We will issue you an RMA number with instructions.

- Phone: 888-525-7300
- Email: sales@apgsensors.com
- Online chat at www.apgsensors.com

## 11 Removal Instructions

Removing your pressure transducer from service must be done with care. It's easy to create an unsafe situation, or damage your sensor, if you are not careful to follow these guidelines:

- Make sure the pressure is completely removed from the line or vessel where your sensor is installed. Follow any and all procedures for safely isolating any media contained inside the line or vessel.
- Remove the sensor with an appropriately sized wrench (per your process connection).
- Clean the sensor's threads of any sealant compound or tape. Inspect the threads and the diaphragm for any damage.
- Store your sensor in a dry place between  $-40^{\circ}\text{F}$  and  $180^{\circ}\text{F}$ .

**DANGER:** Removing the pressure transmitter while there is still pressure in the line or vessel could result in injury or death.

### Non-Incendive Wiring (4-20mA Output)

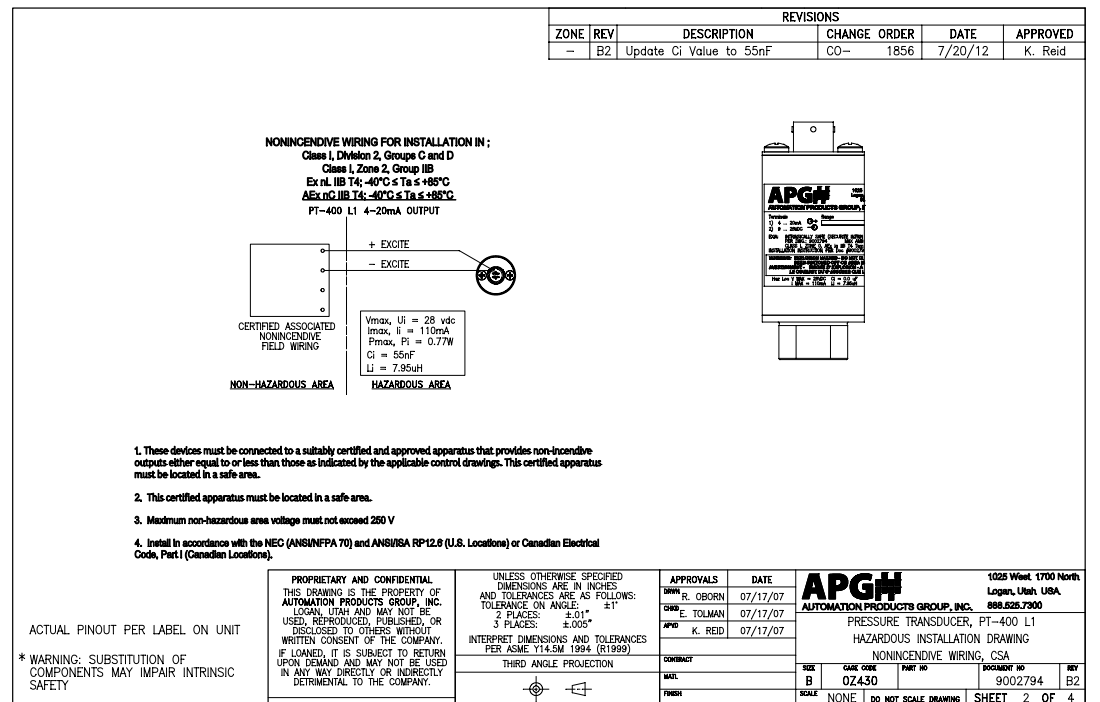

### Non-Incendive Wiring (0-5 VDC Output) [includes 0.5-4.5 VDC and 1-5 VDC]

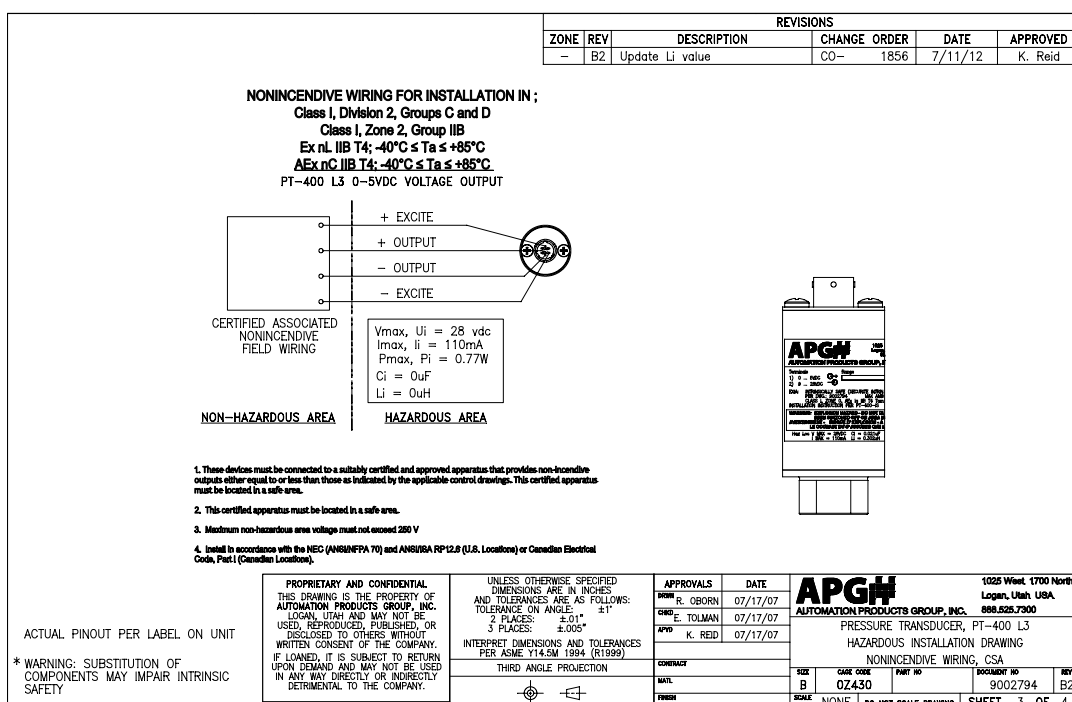

### Non-Incendive Wiring (0-10 VDC Output)

