

PALMER

Palmer Piston Type Snubbers offer the protection you need for your instruments.

Piston Type Snubbers

All products from Palmer Wahl are constructed of the finest materials and designed for reliable service in severe environments. However, some applications occasionally arise where additional protection is needed. Where rapid pulsations or hydraulic hammering is likely to be encountered, a Snubber is recommended to protect the pressure gauge.

Palmer Piston Type Snubbers, unlike sintered metal snubbers, resist clogging and are self-cleaning. During rapid fluid flow, the floating piston is forced up against the orifice, choking the flow and protecting the gauge. By changing the diameter of the piston, the system can be "tuned" to your specific working fluid. The Snubber comes with five different pistons which are easily changed in the field. Recommendations for Pistons are included in the table below.

Material Specifications: Model Numbers and Pressure Ratings are displayed below.

Piston Type Snubbers Model Numbers and Specifications			
Part No.	Size	Material	Rating
1300	1/4" NPT	Brass	9,000 PSI
1325	1/4" NPT	Brass	6,000 PSI
1335	SAE J1926 - 3:7/16-20	Brass	6,000 PSI
1350	1/2" NPT	Brass	6,000 PSI
5025	1/4" NPT	316 SS	15,000 PSI
5035	SAE J1926 - 3:7/16-20	316 SS	8,000 PSI
5050	1/2" NPT	316 SS	15,000 PSI

Piston Type Snubbers Dimensions				
Size	J	K	L	M
1/4" NPT	1.60" (40.6mm)	1.04" (26.4mm)	0.56" (14.2mm)	0.812" (20.6mm)
1/2" NPT	1.875" (47.6mm)	1.25" (31.8mm)	0.625" (15.9mm)	1.125" (28.6mm)
SAE J1926 - 3:7/16-20	1.60" (40.6mm)	1.24" (31.5mm)	0.36" (9.1mm)	0.812" (20.6mm)

Piston Recommendations	
Piston	Suggested Use
A, B*	Gases
B*, C	Water
C, D	Light Oil
E	Heavy Oil

*Snubber assembled and shipped with the "B" piston installed.

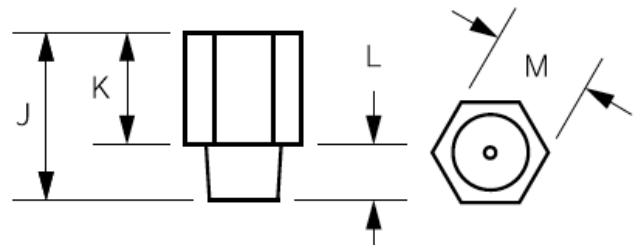
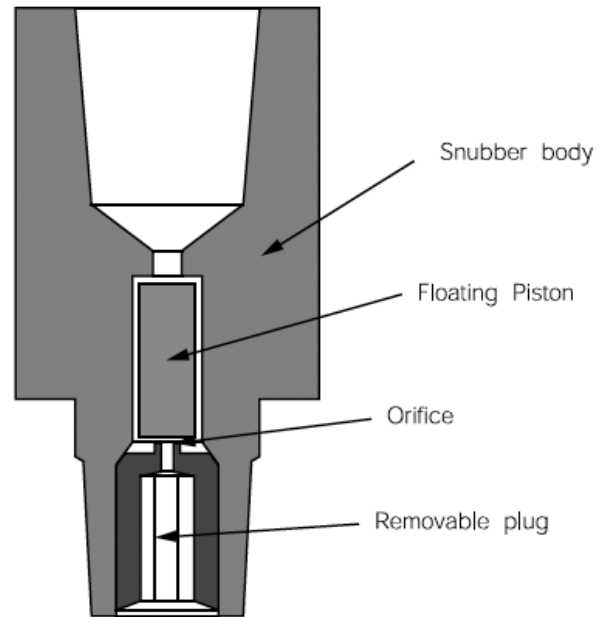

Specifications subject to change without notice. Minimum order quantities may apply.

June 2021

Palmer Wahl Instruments, Inc. • Toll Free: 800-421-2853 • Phone: 828-658-3131 • www.palmerwahl.com

Palmer Wahl
BEYOND THE SCALE

PALMER

Palmer Pigtail Steam Syphons offer the protection you need for your instruments.

Pigtail Steam Syphons

All products from Palmer Wahl are constructed of the finest materials and designed for reliable service in severe environments. However, some applications occasionally arise where additional protection is needed. 180° Coil Style Steam Syphons, also called "pigtail" syphons, should be given serious consideration whenever steam pressure measurement is required. By filling the coil with water, a protective barrier is formed between the high temperature steam and the instrument.

Material Specifications are displayed in the table below.

Pigtail Steam Syphons Model Numbers and Specifications			
Part No.	Model	Pressure Rating	Material
1025	1/4" NPT	308 PSI @ 400°F	Carbon Steel Carbon 40
1050	1/2" NPT	1097 PSI @ 400°F	Carbon Steel Schedule 80
2025	1/4" NPT	552 PSI @ 400°F	316SS Schedule 40
2050	1/2" NPT	1967 PSI @ 400°F	316SS Schedule 80

High Pressure version available. Contact Customer Service for information.

Pigtail Steam Syphons Dimensions		
Size	A	B
1/4" NPT	5.80" (147.3mm)	2.50" (63.5mm)
1/2" NPT	9.00" (228.6mm)	4.50" (114.3mm)

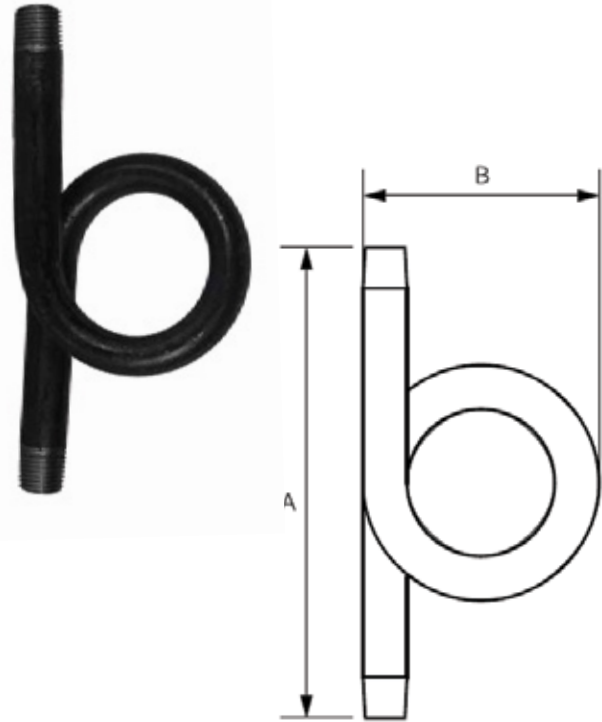

Specifications subject to change without notice. Minimum order quantities may apply..