



TKB SERIES BATTERY OPERATED FLOW METER



The TKB Series Paddle Wheel Flow Meter has been Factory Programmed → No K-Factor Programming Required

Important !



To Ensure Full Pipe → Please Follow the Installation Instructions on (pg 6)

Instruction Manual



TKB Series Battery Operated LCD Flow Meter

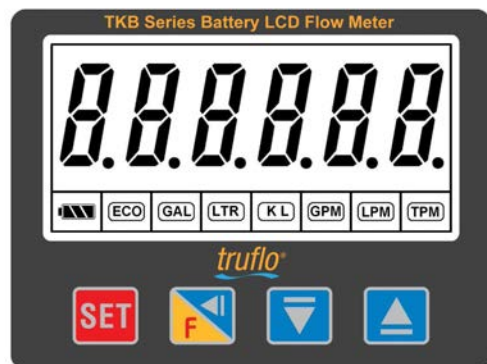

Features

1. Energy Saving 'ECO' Mode Option
2. Units of Measurement
 - 2-1. Flow Rate || GPM | LPM | TPM | Range 0.0~999.9
 - 2-2. Totalizer || GAL | LTR | KL | Range 0~99,999,999
3. Totalizer Reset Protection
4. Four Directions for Installation-90 Degrees 
5. Low Battery Indication
6. Eprom Memory- Retains Setting during Battery Change-out
7. High | Low Level Alarm

Model Selection

TKB - 15 - PF - V - S				
1	2	3	4	5
1	Series	TKB Battery Operated LCD Flow Meter		
2	Pipe Size	「08」= 「DN08 (1/4)」* / 「10」= 「DN10 (3/8)」* / 「15」= 「DN15 (1/2)」 / 「20」= 「DN20 (3/4)」 「25」= 「DN25 (1)」 / 「40」= 「DN40 (1 1/2)」 / 「50」= 「DN50 (2)」 / 「65」= 「DN65 (2 1/2)」 「80」= 「DN80 (3)」** / 「100」= 「DN100(4)」**		
3	Body Material	「PVC」= PVC / 「PP」= PP / 「PF」= PVDF / 「ST」= SUS 316		
4	O-Rings Seals	V Viton*** E EPDM		
5	End Connections	PVC S: SOC T: NPT F: Flanged PP PVDF T: NPT B: Butt F: Flanged 316SS T: NPT S: Sanitary F: Flanged		

General Data

* SST Version Only | Note: Sanitary and Flanged Connections Size 1/2" - 4" Only
 ** Plastic Versions Only *** Viton is Standard

Specification	Description
Fluid	Liquids Viscosity Range: .5-20 centistokes
Accuracy	± 0.5% of F.S. @ 25°C
Max Flow Velocity	10 m/s max
Low Cut-Off	0.3 m/s min.
Operating press.	150 PSI (10 Bar) @ Ambient Temperature Non Shock
Range Turn-Down	10 : 1
Response time	Real Time
Materials of Construction	Paddle Tefzel Bodies PVC PP PVDF SUS 316 Rotor Bearings Zirconium Ceramic
Operating Temperature	「PVC」 < 60°C / 「PP」 < 80°C / 「PVDF」 < 110°C / 「ST」 < 120°C
Ambient Temperature	-20°C ~ +80° 35% ~ 85% RH
Protection Class	NEMA 4X IP-66
Approval	CE Rohs

Specification

Product	TKB Series Battery Operated LCD Flow Meter
Model	TKB-□□□
Flow Total (Totalizer)	Range = 0~999999 Programmable Unit = Gallon Liter KL
Flow Rate	Range = 0.0~999.9 Programmable Units = GPM LPM TPM
Operating voltage	3.0 VDC
Battery	Lithium Battery (CR2477T)
Life of battery	> 2 Years Under Normal Operating Conditions
Housing material	Polycarbonate (UL-94V0)

Outline Dimensions

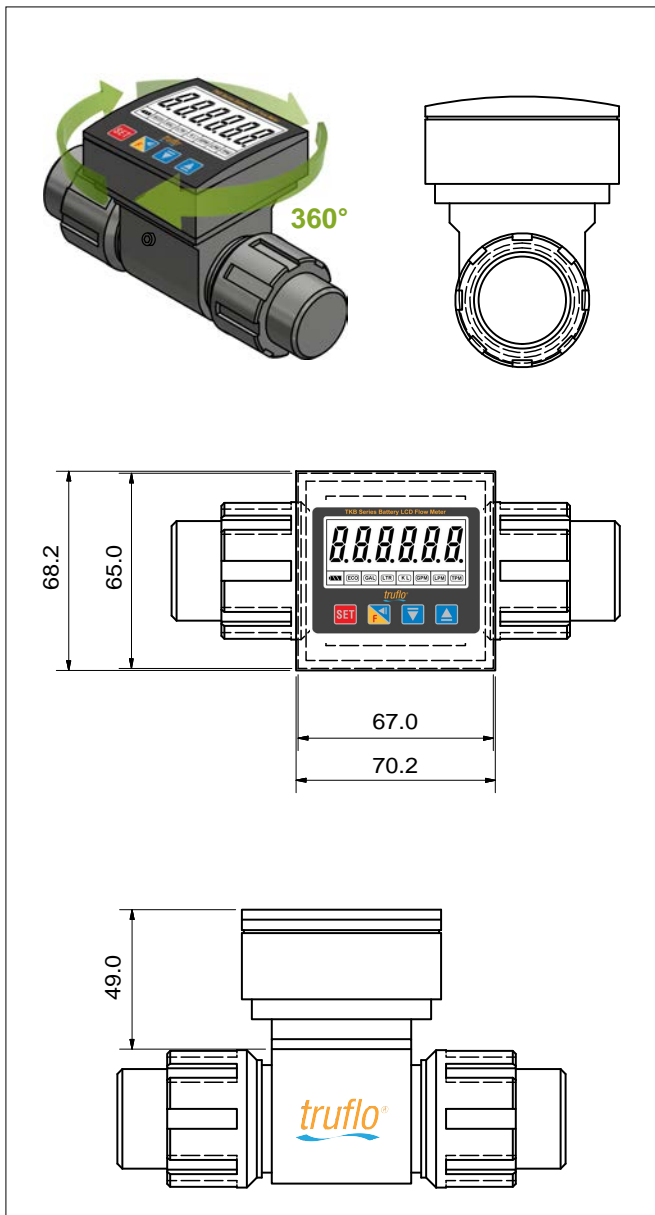

Parts List



Programming * Units come Factory Preprogrammed | No K-Factor Programming is Required

SETUP	SELECTION	DESCRIPTION
<p>Flow Rate or Flow Total Display Flashing</p> <p>Press & Hold (3 Sec) Press to Scroll Between Flow Rate and Flow Total (Totalizer) </p>	<p>0~999999 or 0.1~9999.9</p>	<p>Battery Installed LCD Display On r = Flow Rate Default Setting</p>  <p>Press & Hold (3 Sec) Press to Scroll Between Flow Rate and Flow Total (Totalizer)</p>
<p>Set Password Enter #</p> <p>Press & Key for 5 sec</p> <p>1. or Press to Select</p>	<p>Programmable 0~9</p>	<p>Factory Unlock Number is 8 Enter ANY Number from 0- 9 to Set Password #</p>
<p>Changing K Factor K = #</p> <p>2. Press key or Display Flashing Press to Select</p>	<p>Factory Preset</p>	<p>1. Flow Coefficient = Input pulses x 1/k * <small>Only required if changing displays from one size to another i.e. 1" to 2" pipe size</small></p>
<p>Display Mode dSP.non</p> <p>3. Press key or Display Flashing Press to Select</p>	<p>Selectable dSP-non dSP-Eco</p>	<p>1. dSP-non Press any key to turn on the LED back light Default is set to 6 seconds 2. dSP-Eco Backlight LED function is not active</p>
<p>Light On t-5</p> <p>4. Press key or Display Flashing Press to Select</p>	<p>Programming Backlight 'ON' Time 1~9999</p>	<p>In dSP-non mode Backlight default is t-0006 Set Duration Time (sec) of Backlight to remain On. Press any key to turn on the display to turn on LED light (> Time = < Reduced Battery Life)</p>
<p>Flow Alarm Delay dt-10</p> <p>5. Press key or Display Flashing Press to Select</p>	<p>Programming Alarm Delay time (sec) 1~9999</p>	<p>Delay Time ensures Alarm Setting only becomes active after the flow remains constant for xx seconds Programming the High Low Alarm Press + 3 Sec to Display High Alarm Setting Press or to Enter Alarm Value. Press to Display Low Alarm Setting. Press or to Enter Alarm Value. The Press to Confirm</p>
<p>Reset Totalizer rESEt.0</p> <p>5. Press key or Display Flashing Press to Select</p>	<p>Programming Totalizer Password 1~9999</p>	<p>1. To Prevent Totalizer reset - Enter Password Number 0-9 (excluding # 5) Flow Totalizer Reset Protection Active 2. rESEt.= 5 Default = Flow Totalizer Reset Enabled</p>

Selection of the Engineering Units for Flow Rate | Flow Total

Press **SET** Key for 3 Seconds, then press or to select



Flow Rate Units → Flow Total | Totalizer Units →

GPM → LPM → TPM → GAL → LTR → KL → GPM

3. Display the Current Value of Flow Totalizer : Range 0~99,999,999

3-1. Please press the  key for 3 seconds to show current value of the 7th ~ 8th digits





3-2. After releasing the  key the current value of the 1st ~ 6th digits will be displayed

4. Totalizer Reset | Password Protection Feature

4-1. The Flow Total (Totalizer) can be Protected from an Accidental Reset. To set lockout program any number from 0-9 excluding (# 5) The Unlock Number = (5) Factory Default

  **Totalizer Reset** → Press Both  &  Keys Together for 3 Seconds

5. Battery Life Notification

Voltage of battery	Symbol of battery	Status
3.0V		Full scale
< 3.0V		Mid scale
<2.8V		Low Scale (Pilot BAT Flashing)
<2.6V		Low Voltage (Pilot BAT & Display Flashing)

6. Displaying Flow Rate | Flow Totalizer

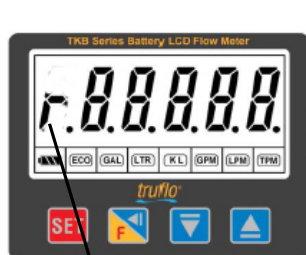

 r indicates Default Flow Rate Mode

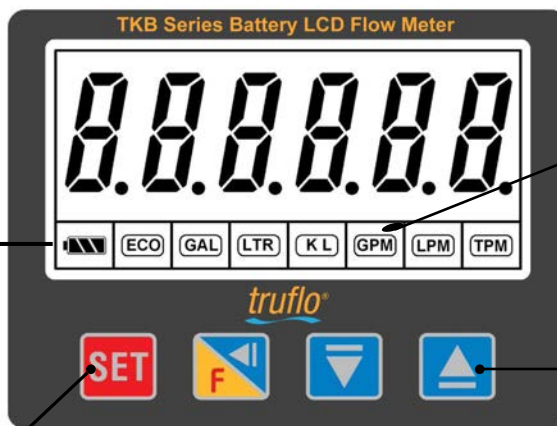

Highlighted to Indicated Programmed Unit of Measurement

Press & Hold for 3 Seconds to view 8+9 digits while in Totalizer Screen

 Press and Hold Set for 3 Sec to Change from Flow Rate to Flow Total

Mode of Operation (Eco) = Extended Battery Life



Battery Life

Flow Total

Flow Rate

Battery Replacement

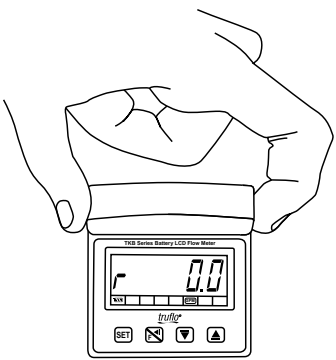
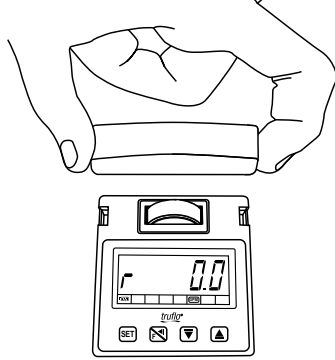
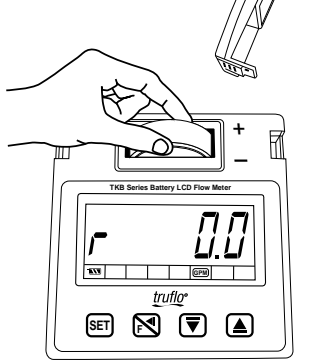
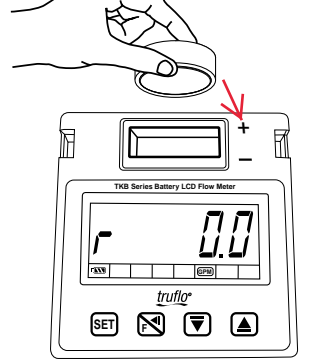
<p>1 Lightly Press on Both Sides Battery Cover</p> 	<p>2 Remove the Battery Cover</p> 	<p>3 Remove the Battery</p> 	<p>4 Insert the New Battery Ensure (+ -) orientation is correct</p> 
--	--	---	---

Procedure to Rotate Display

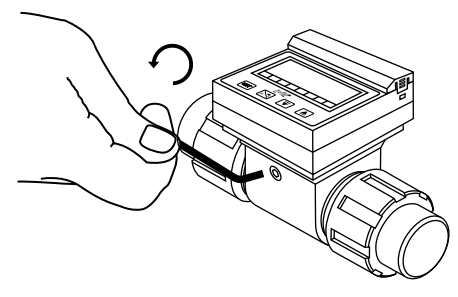
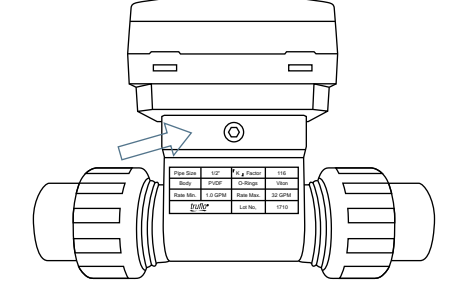
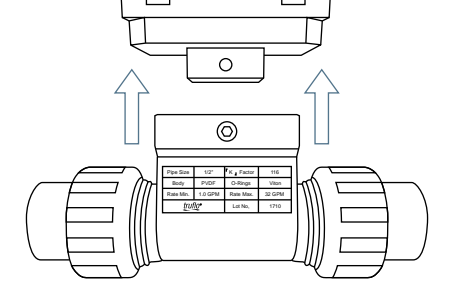
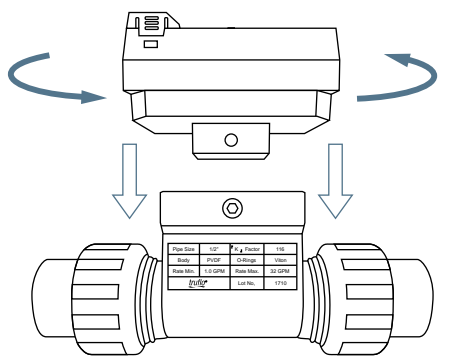
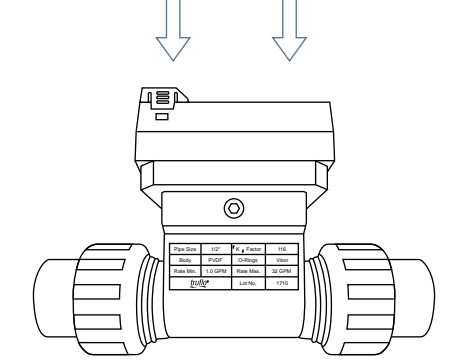
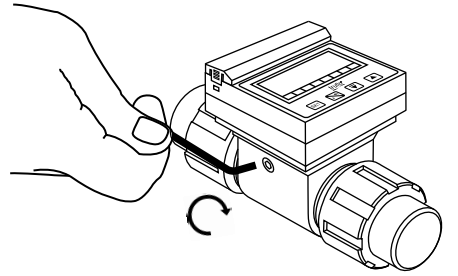
<p>1 1. Use an Allen key and loosen the screws located on both side of the display</p> 	<p>2 2. Lightly pull on the screws in an outwards direction Screws are Captive - Do Not Completely Remove</p> 	<p>3 Lift the display</p> 
<p>4 Rotate Display</p> 	<p>5 Reposition the Display</p> 	<p>6 Tighten (Snug) the Allen Screws Both Sides</p> 

Installation Positions

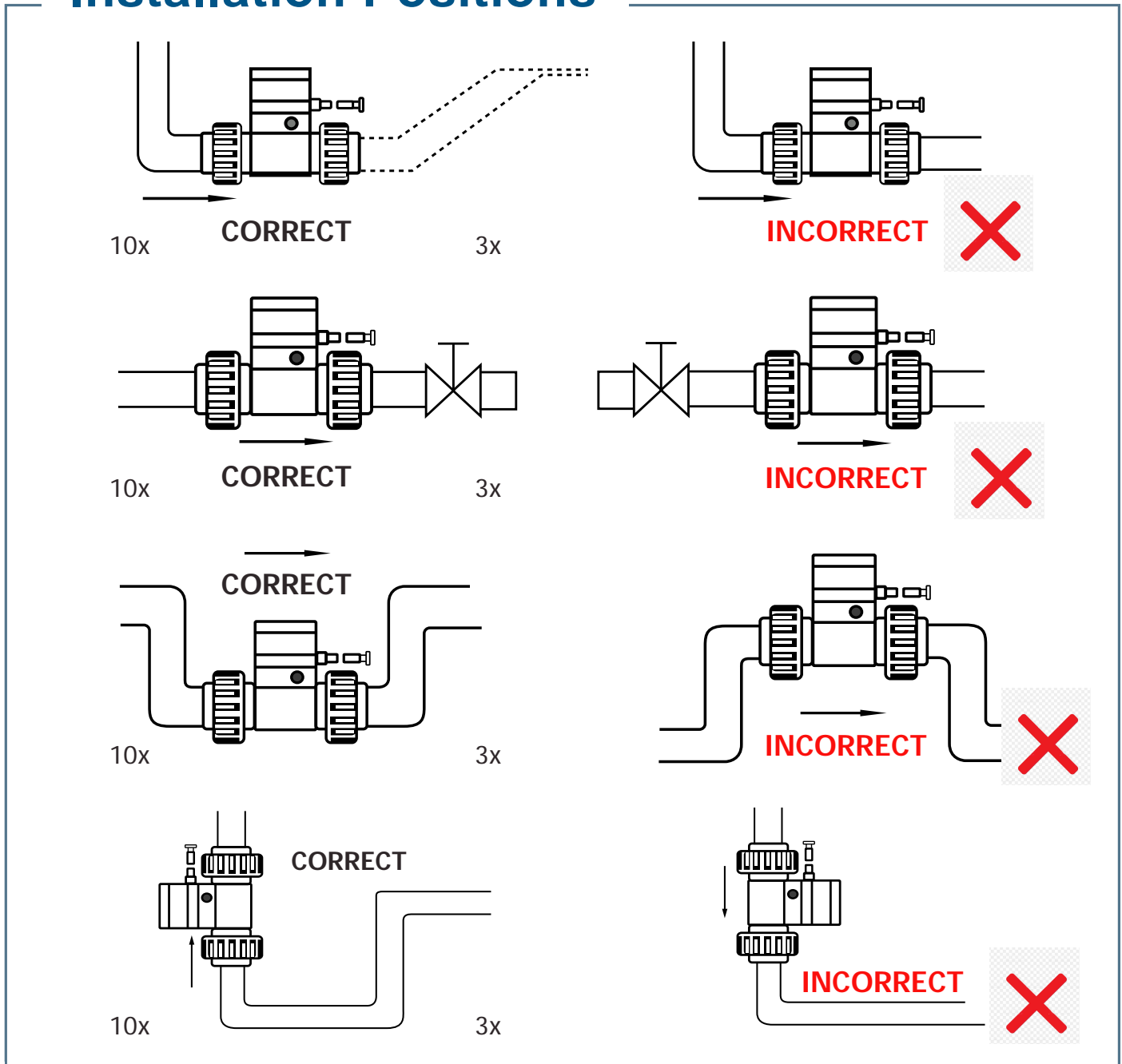

Please Ensure the **PIPE** is **FULL** with the fluid under normal operation.

Min 10x Pipe Diameters Upstream **3x** Pipe Diameters Downstream.

TKR Series can be installed in a Horizontal or Vertical direction.

A Plastic Basket Strainer, Bag Filter or Y Strainer Filtering Device upstream to Avoid the Paddle Wheel from being damaged by the solids or fibers - max 10% Particle Size - Not to Exceed .5mm Cross Section or Length.