



TM630 and TM630A

Pocket Thermocouple and RTD Thermometer



User Manual

WD1021 Rev F
04/08/15

TM630

Acknowledgements

Thank you for choosing this Wahl Instruments high accuracy measuring instrument. Wahl has been providing high quality, high accuracy measuring instruments for over 50 years.

Because of this, we are able to continue our policy of continuous innovation, which has served our customers so well for the last 50 years. Wahl Instruments encourages your comments and would willingly accept any suggestions from you to help us to perfect our know-how and improve our future products

LIMITED GUARANTEE LIMITED LIABILITY

Manufacturer warrants the TM630 Thermometer and RTD Thermometer to be free from defects in material or workmanship under normal use and service for a period of 12 months from date of purchase. The Manufacturer agrees to repair or replace any product, which upon examination is revealed to have been defective due to faulty workmanship or material if returned to our factory, transportation charges prepaid, within the above stated warranty period. This warranty is in lieu of all other warranties, expressed or implied and of all obligations or liabilities on its part for damages including but not limited to consequential damages, following the use or misuse of instruments sold by the Manufacturer. No agent is authorized to assume for Manufacturer any liability except as set forth above.

Unpacking Contents

The TM630 (all references to the TM630 also include the TM630A unless otherwise indicated) was checked mechanically and electrically prior to shipment. The necessary precautions have been taken to ensure it reaches the user without being damaged.

Nonetheless, it is wise to make a quick check to detect any damage, which may have occurred during transport. If this is the case, inform the carrier immediately thereof.

The standard accessories are the following:

- This user's guide
- 4 AA batteries (1.5V).
- Wrist strap.
- Rubber boot

**WARRANTY & CALIBRATION
REGISTRATION at**
www.palmerwahl.com/register

Registration is fast and easy. In about a minute you can have your product automatically registered for Warranty Protection and our Calibration Reminder service. Let Palmer Wahl help you protect your investment, and maintain product accuracy and compliance with ISO and other quality standards.

Questions? Call Customer Service at 1-800-421-2853 or 828-658-3131, Or email: register@palmerwahl.com

If service or re-certification of your instrument is needed, please contact us via phone, fax or e-mail, for a Return Material Authorization (RMA) number.

If the unit is to be returned, it is preferable to use the original packaging and return with transportation charges prepaid.

Wahl Instruments, Inc.
234 Old Weaverville Road
Asheville, NC 28804 USA

Phone: 800.421.2853
828.658.3131
Fax: 828.658.0728
e-mail: rma@palmerwahl.com
website: www.palmerwahl.com

Contents

A.	General	5
A.1	Introduction	5
A.2	Parts	5
A.3	Safety	5
A.3.1	Compliance with safety standards	5
A.3.2	Environmental conditions	6
A.3.3	Worn devices	6
A.3.4	Device destruction procedure	6
A.3.5	Instructions	6
A.3.6	Making measurements	6
A.3.7	Defects and abnormal stresses	6
A.3.8	Definitions	7
A.4	Maintenance	7
B.	Using the instrument	8
B.1.1	The keyboard	8
B.1.2	The measuring and simulation terminals	9
B.1.3	The USB connector	12
B.1.4	The screen	12
B.1.5	Getting started (after power-up)	13
B.1.6	Main characteristics	13
C.	Mode Programming	15
C.1.1	Voltage or temperature measurement by thermocouple	15
C.1.2	Resistance or temperature measurement using resistive sensors	16
D.	Related Functions	19
D.1	Scaling	19
D.2	Differential measurements	20
D.3	Calibrated sensors	21
D.4	Storage of acquisitions in progress.	24
E.	Parameter settings	30
E.1	Contrast adjustment	30
E.2	Date and time setting	30
E.3	"Preferences" setting.	31
E.3.1	Filtering setting.	31
E.3.2	Display resolution setting.	31
E.3.3	Lighting duration setting.	31
E.3.4	"Key beeping" setting.	31
E.3.5	Language setting	32
E.3.6	Temperature unit setting	32
E.4	"Maintenance" menu	32
E.4.1	Adjustment from the Maintenance menu	33
E.5	"About the instrument" menu	35
F.	Software Update	36
G.	Technical specifications	37
G.1	Measurement Function	37
G.1.1	Constant voltage	37
G.1.2	Temperature per thermocouple.	37
G.1.3	Resistance	38
G.1.4	Temperature by resistive sensors.	38

A. GENERAL**A.1 Introduction**

The TM630 is a portable resistive sensor temperature tester (compliant with EC standards). It is especially designed for calibration and maintenance. It makes it possible to measure and to simulate temperatures both on site as well as in a laboratory.

The TM630 features a large number of related functions which extend its range of application:

- Storage of acquisitions and display in the form of tables or trend curves.
- Use of calibrated sensors with their coefficients of correction

A range of improvements facilitates its operation:

- Rapid access to all functions.
- Intuitive user interface.
- 160x160 graphic display
- Connection via 4 mm safety plugs or a miniature flat plug.
- Power supply via 4 AA batteries or rechargeable batteries with internal charger (Option).

The device is housed in an ABS case with a rubber boot.

A.2 Parts

General characteristics:

- Portable device powered by 4 AA batteries (pack of Ni-MH storage batteries, 1.7 Ah optional).
- Hand strap for carrying and use on-site
- Graphic liquid crystal display: 160 x 160 pixels.
- Choice of language used for messages and programming of functions, gauges and parameters via 6-key keyboard + 1 navigator.
- Backlit display accessible via a keyboard key, with the possibility of automatic black-out after a specific programmable period of inactivity.
- Appearance: ABS case (elastomer-sheathed).
- Dimensions: 6.18 x 3.35 x 1.77 inches (157 x 85 x 45 mm) (without rubber boot).
- Weight: 10.8 oz. (306 g) without rubber boot.
- IP54 rating in compliance with standard EN 60529

Accessories:

Part No.	Name
12436-01	Rechargeable battery pack with charger
12436-04	4 pin RTD connector (mating plug) for TM612 and TM630 (and TC622)
12436-05	Carrying Case, hard plastic
12436-06	Rubber boot (replacement)
12436-07	Cable, USB2.0A to Mini USB Type B, 5pin, 6 ft. length
12436-32	4 pin RTD connector (mating plug) for TM612A and TM630A (and TC622A)

A.3 Safety**A.3.1 Compliance with safety standards**

The device complies with the applicable standards in force on the subject of electrical safety (EN 61010) as well as on the electromagnetic compatibility of the electrical measuring instruments (EMC: EN61326).

These instructions for use contain information and warnings which must be observed by the user to protect the latter against the dangers of electricity, to ensure the safe operation of the device and to protect it against any mishandling which could damage or compromise the safety of use of the device.

A.3.2 Environmental conditions

In accordance with publication CEI 359: operating category I.

Range of application of standards from 0 to 2,200 m.

Reference temperature range: 23°C ± 5°C, relative humidity: 45 % to 75 %.

Nominal operating range: -10°C to +50°C, relative humidity: 20 % to 80 % non-condensing.

Operating range limit: -15°C to +55°C, relative humidity: 10 % to 80 % (70 % at 55°C).

Storage and transport temperature range limit: - 30°C to + 60°C (without the batteries).

A.3.3 Worn devices

Worn electrical devices can pollute the environment. We recommend you refrain from disposing of this device in an ordinary waste bin, but rather that you use the recycling circuits available locally.

A.3.4 Device destruction procedure

Opening the device: unscrew the screw on the battery compartment, followed by the 5 screws securing the 2 shells.

Separate the 2 shells. Separate the PCB from the upper shell.

With regard to the batteries, you will find them in the battery compartment (see commissioning chapter).

In the case of the pack of batteries, there are 2 contaminants: Ni-MH (Nickel-Metal Hydride) batteries and a PCB. Separate these 2 items.

A.3.5 Instructions

The device was designed to operate safely if the instructions provided in the accompanying documents are followed. Any other use may jeopardize the safety of the operator. Any use other than those specified in the instructions is therefore dangerous and forbidden.

A.3.6 Making measurements

The measuring leads and wires must be in good condition and must be replaced if their insulation appears faulty (insulating material cut, burned, etc).

Never exceed the protection value limits indicated in the specifications.

Before changing function, disconnect the measuring wires from the external circuit. When voltage measurements are being made, even weak ones, keep in mind that the circuits may contain a dangerous voltage for the operator when referenced to ground.

Do not make any measurements when the device is linked up to another device using the USB link or when the batteries are being charged.

A.3.7 Defects and abnormal stresses

If you believe the device's protection may have been compromised, switch off the device and prevent it from being switched back on unexpectedly.

The protection may be impaired in the following cases, for example:

- ✓ The device is visibly worn.
- ✓ The device is no longer able to make precise measurements.
- ✓ The device was stored in unfavorable conditions.
- ✓ The device has undergone severe stresses during transport.

A.3.8 Definitions

A.3.8.1 Definition of the category and degree of pollution



CAT II 60V:

This notion of categories determines the maximum voltage which can be applied to the measuring inputs (it is also referred to as the over voltage category). For the TM630, the ceiling over voltage is (DC or AC)

POL 2°:

The notion of pollution determines the clearance between circuits. Degree 2 authorizes temporary conductivity caused by condensation.

A.3.8.2 Table of symbols used

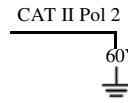
Symbol	Name
	Attention: see the accompanying documents
	Earth
	Compliant with the European Union directives
	Category II, Pollution 2. Maximum common mode voltage compared with the ground=60V

A.4 Maintenance

The device must always be repositioned in accordance with the instructions provided herein. Any incomplete or incorrect assembly could compromise the safety of the operator.

The authority responsible must regularly ensure that all safety-related items are not worn and ensure all the preventive maintenance operations required are performed.

Before opening the device for any maintenance operations, you must make sure that all the wires are disconnected from the appliance.

All adjustments, maintenance and repair work on the open device must be avoided as much as possible and, when these are indispensable, they must be performed by qualified staff, who are well aware of the risks involved.

B. USING THE INSTRUMENT

In order to use the device in a safe manner, all operators must read the paragraph on safety carefully, along with the paragraph below.

B.1 Power-up

The device is delivered with 4 AA batteries of 1.5V each. To install the batteries into the compartment, unscrew the battery compartment screw on the back of the unit. Observe the polarity: an incorrect battery positioning could damage the device. The correct polarity is indicated inside the compartment. Once the batteries are in place, screw the cover back on. The figure below illustrates how to open the battery compartment as well as the correct positioning of each battery.

To turn the unit ON, press the ON/OFF key until the first "Checking EEPROM" screen comes up. (This may require pressing and holding the key for up to 5 seconds.)

To turn the unit OFF, press the ON/OFF key until the "Instrument in power off mode" screen comes up.

Please note: instruments, whose serial number ends in "B", will not retain the time and date when powered off. If time and date need to be retained, the unit can be put in standby mode.

To enter standby mode, press both the HOLD and ON/OFF buttons until the screen displays "Instrument in standby mode".

To return to normal operating mode from standby mode, press the ON/OFF key until the original screen comes up. Please allow a minimum of 10 seconds between going into standby mode and returning from it.



B.1.1 The keyboard

The keyboard features:

- 2 function keys (**F1** and **F2**) for the selection of the various menus displayed on the screen.
- The navigator, consisting of 4 arrows (up (↑), down (↓), right (→), left (←))
- A clear key (**CLEAR**).
- A device on/off and backlighting on/off key (**ON/OFF**).
Press briefly to start the device. During operation, press briefly to turn the backlight on or off. Press it longer for 2 seconds to turn off the device.
- A validation key (**VAL**).
- A HOLD key allows you to suspend a process temporarily (when pressed briefly).



B.1.2 The measuring and simulation terminals

The TM630 is fitted with a miniature flat plug for thermocouples and a 4-point circular connector for RTD probes.

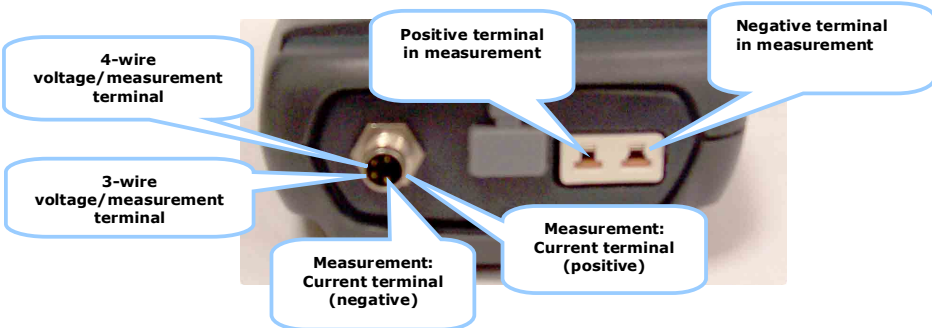

TM630 Connections

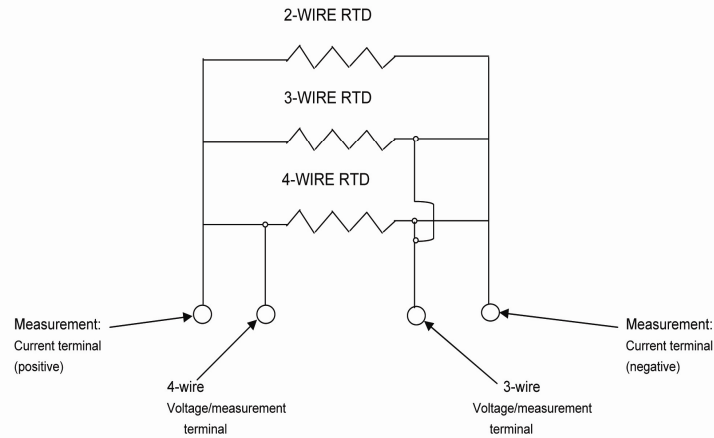

Connections Using Banana Connectors

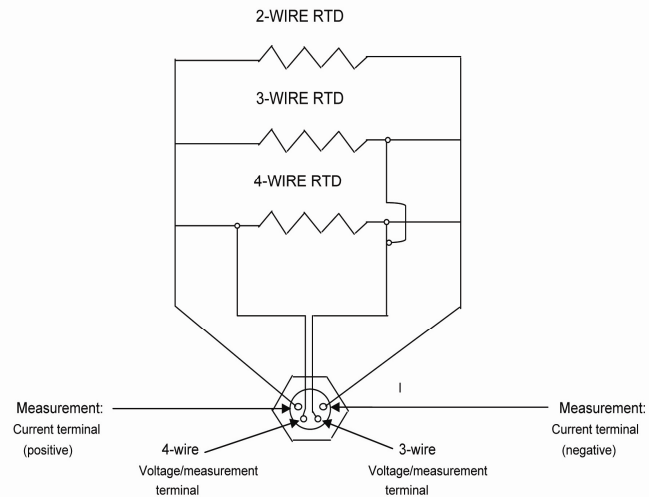

Connections using Circular Connector at Top of Meter

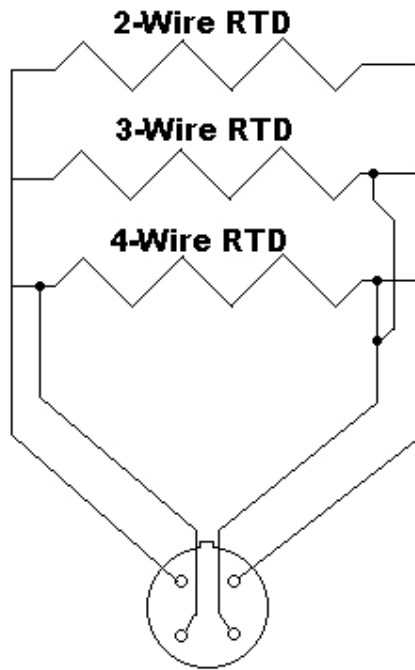

TM630A Connector

B.1.3 The USB connector

The TM630 is fitted with a USB connector (mini B) intended for uploading new software versions and device adjustment.



USB port (mini B connector)

B.1.4 The screen

The TM630 is fitted with a graphic LCD display with back-lighting. The display resolution is 160 x 160 pixels. In normal operating conditions, the display is divided up into seven horizontal fields:

- The 1st field indicates the operating mode (Measurement).
- The 2nd field indicates the date, time and battery charge.
- The 3rd field is reserved for icons indicating the operating mode (related functions: Scaling, filtering, etc).
- The 4th field indicates the operating mode, the gauge and certain related functions.
- The 5th field indicates the value of the measurement or of the emission. These values are expressed in mV, °C, °F or as a %.
- The 6th field indicates (in measurement mode) the minimum, average and maximum values of the measurement.
- Lastly, the 7th field indicates the functionality of keys **F1** and **F2**.

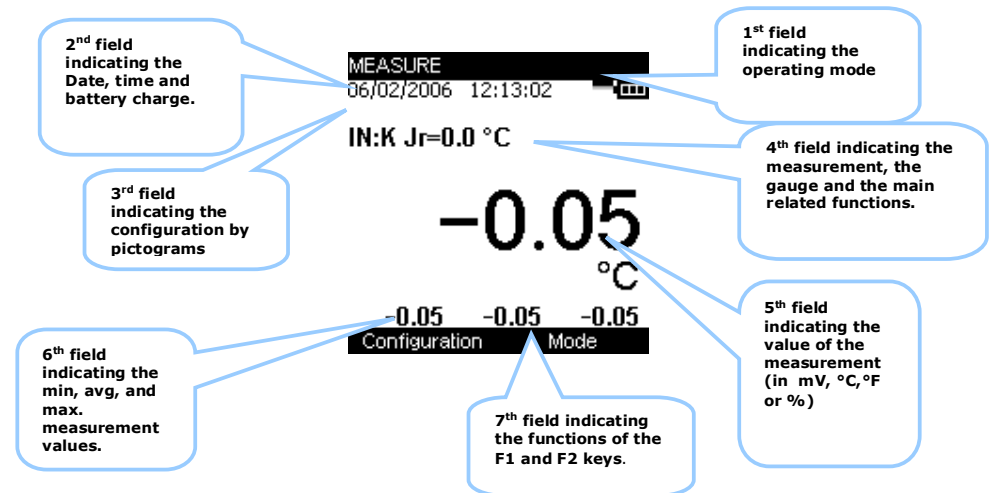

The table below provides a definition of each pictogram displayed on the screen:

Symbol	Description
	Scaling
	On hold
	Filtering
	%FS function (Full Scale)
	Incremental mode using the arrows
	Error Condition - - - - - indicates open input or extreme over-range of instrument (negative symbol with 6 dashes) + : - - - - - indicates measurement is over- range of instrument (positive symbol, colon and 5 dashes) - : - - - - - indicates measurement is under-range of instrument (negative symbol, colon and 5 dashes)
	Battery life indication
	Acquisition in progress (the value on the right of the pictogram indicates the number of values recorded)

The table below provides a definition of each pictogram of the function keys

Symbol	Description
	Tab key
	Open a drop-down list
	Close a drop-down list
	Delete the selected item
	Clear the selection
	Add the item being edited

B.1.5 Getting started (after power-up)

On power-up (inserting the batteries or pack of batteries), the device is automatically turned on (loading the software in the memory).

B.1.6 Main characteristics

B.1.6.1 Constant voltage measurement

Gauge	+100mV
Resolution (display)	1 μ V or 0.01 $^{\circ}$ C or 0.01 $^{\circ}$ F
Scope of range:	-10 mV to + 100 mV
Scaling	yes

B.1.6.2 Resistance/temperature measurement The following gauges are available:

Gauge	400 Ohm (for PT100)	3600 Ohm (for PT1000)
Resolution (display)	10 m Ω or 0.01 $^{\circ}$ C or 0.01 $^{\circ}$ F	100 m Ω or 0.01 $^{\circ}$ C or 0.01 $^{\circ}$ F
Scope of range:	0 Ω to 400 Ω -220 $^{\circ}$ C to 850 $^{\circ}$ C -220.00 $^{\circ}$ C to 850.00 $^{\circ}$ C	0 Ω to 3600 Ω -220 $^{\circ}$ C to 760 $^{\circ}$ C -220.00 $^{\circ}$ C to 760.00 $^{\circ}$ C
Scaling	yes	yes

B.1.6.3 Electrical characteristics not to be exceeded.

Function	Gauge	Max Min	Z load
V measurement	100mV	60 V	
Ohm measurement	400 Ω /3600 Ω	60 V	

C. MODE PROGRAMMING

C.1.1 Voltage or temperature measurement by thermocouple

- The function type selection (Thermocouple type) is made using the **F1** key (**Configuration** menu).
- Using the navigation keys (**↑** and **↓**), position the cursor in the **Function** field.
- Confirm the latter using the **VAL** key.

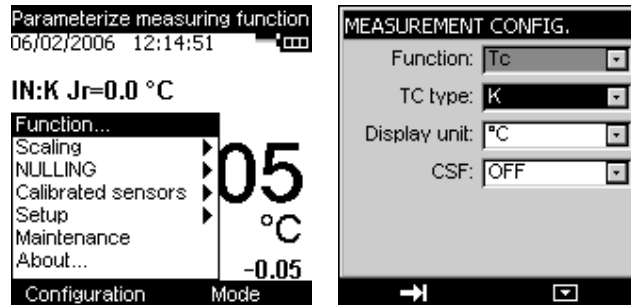

- In the **MEASUREMENT CONFIGURATION** menu, go to the **Function** field.
- Enter the **Function** field using the **F2** key.
 - Using the navigation keys (**↑** and **↓**), select the TC (for thermocouple) function type. Press **VAL**.

Position the cursor in the **TC type** field using the **F1** key.

- Enter the **TC type** menu using the **F2** key.
- Choose the type of thermocouple (**K, T, J...**), using the navigation keys (**↑** and **↓**).

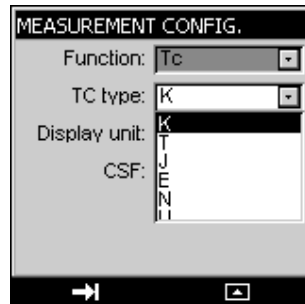

- Press **VAL** to confirm.
- Using the **F1** key, define the **Display unit** by positioning the cursor on it.
- Enter the menu by pressing **F2**.
- Using the navigation keys (**↑** and **↓**), select the unit.
- Press **VAL** to confirm.

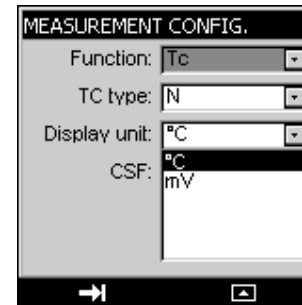

Attention, the choice of °C or °F is made in the **Setup\Preferences\unit of temp** menu

- Using the **F1** key, define the **CSF** used by positioning the cursor on it.
- Enter the menu by pressing **F2**.
- Using the navigation keys (**↑** and **↓**), choose the **CSF** (**OFF**: None, **ON**: internal or programmed).
- Press **VAL** to confirm.
- Press **VAL** (again) to confirm the desired function and go back to the measurement screen.

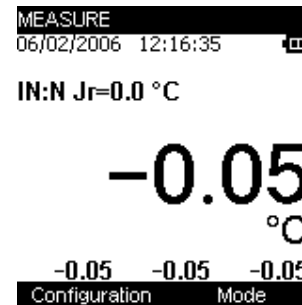

The **Measurement** mode makes it possible to display the Minimum (bottom left), Average (bottom center) and Maximum values (bottom right) from the last **Min/Max reset** command.

- Access this command by pressing the **F2** key.
- Using the navigation keys (**↑** and **↓**), position the cursor in the **Min/Max reset** field.
- Confirm the latter using the **VAL** key.

Note:

Following a significant thermal shock, it is advisable to allow the device to stabilize its temperature to use the internal reference junction (CSF) with the utmost precision.

C.1.2 Resistance or temperature measurement using resistive sensors

- The function type selection (Resistive sensor type) is made using the **F1** key (**Configuration** menu).
- Using the navigation keys (**↑** and **↓**), position the cursor in the **Function** field.
- Confirm the latter using the **VAL** key.

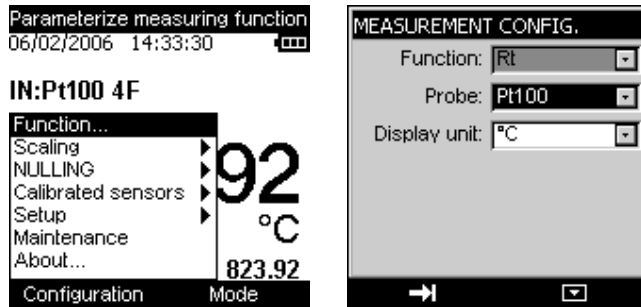

- In the **MEASUREMENT CONFIGURATION** menu, go to the **Function** field.
- Enter the **Function** field using the **F2** key.
 - Using the navigation keys (**↑** and **↓**), select the **Rt** (for resistive probe) function type. Press **VAL**.

Position the cursor in the **Probe** field using the **F1** key.

- Enter the **Probe** menu using the **F2** key.
- Choose the type of sensor (PT50, PT100, PT200, etc.), using the navigation keys (**↑** and **↓**).

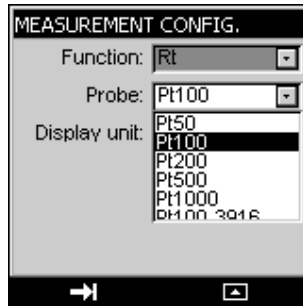

- Press **VAL** to confirm.
- Using the **F1** key, define the Display **unit** by positioning the cursor on it.
- Enter the menu by pressing **F2**.
- Using the navigation keys (**↑** and **↓**), select the unit.
- Press **VAL** to confirm.

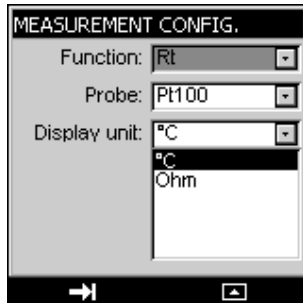

Attention, the choice of °C or °F is made in the **Setup\Preferences\Unit of temp.** menu.

- Press **VAL** (again) to confirm the desired function and go back to the measurement screen.

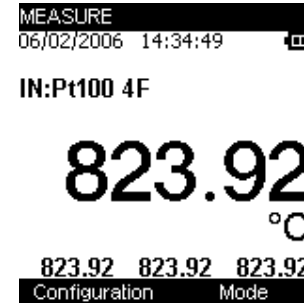

The **Measure** mode makes it possible to display the Minimum (bottom left), Average (bottom center) and Maximum values (bottom right) from the last **Min/Max reset** command.

- Access this command by pressing the **F2** key.
- Using the navigation keys (**↑** and **↓**), position the cursor in the **Min/Max reset** field.
- Confirm the latter using the **VAL** key.



D. RELATED FUNCTIONS

D.1 Scaling

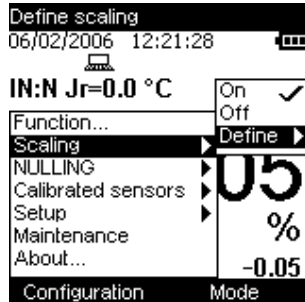
The scale correction function performs conversion operations between the electrical values measured and the physical values converted. This linearization operation makes it possible to correct the errors induced by non-linear sensor/converter systems. The Scaling function allows definition of up to 11 correction values, i.e. 10 segments, in order to approach as much as possible the non-linear response curve, and to make the scale corrections according to each defined segment. The pictogram  is displayed on the screen in the active window when the scaling function is enabled.



The **Define/list of points** menu makes it possible to program up to 10 lines of 2 values: X and Y= f(X). In measurement mode: X = Value measured and Y = Value Displayed. The lines entered are sorted according to the X in increasing order, to scale an X-value, the device seeks the 2 lines n and m=n+1 which frame it, and extrapolates linearly: $Y = Y_n + (X-X_n) \times (Y_m-Y_n)/(X_m-X_n)$. Use the function keys to edit the points:

- To add a line: enter X and Y, then press the  function key.
- To select a line in a list, use the Up and Down navigation keys.
- To delete a selected line, use the  key.
- To move from one field to the next, use the  key.

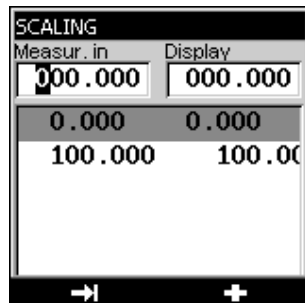

The **Define/parameters** menu makes it possible to define the format (Number of digits displayed) and unit.

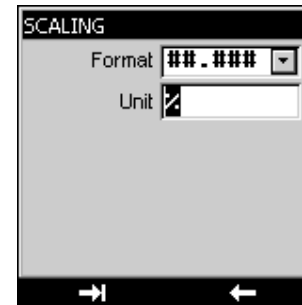

Once the parameters have been set, the scaling is automatically enabled. To disable it, enter the **Configuration/Scaling** menu, select **OFF** and confirm by pressing the **VAL** key.

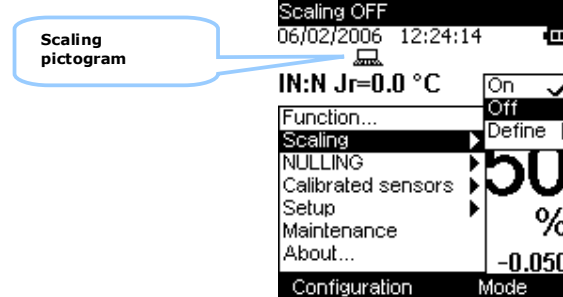

D.2 Differential measurements

The relative measurement function available on the device makes it possible to cancel a constant or spurious value via programming. Selecting ON will null out the Defined parameter value. Selecting Tare will null the current value displayed and will update the **NULLING/Define...** box with the new value.

When the relative measurement function is enabled, the symbol  is displayed on the measurement screen.

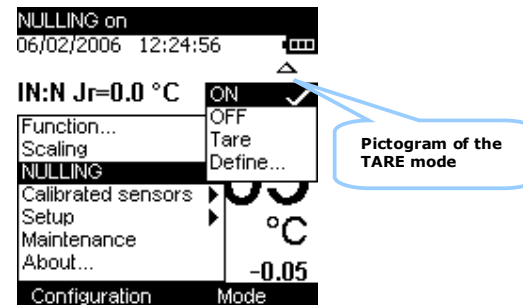

The **NULLING/define** menu makes it possible to program the value of the Tare (positive or negative). This value is subtracted from the measurements:

Value Displayed = Value measured - Value of the Tare

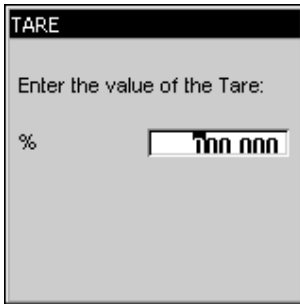

D.3 Calibrated sensors

The calibrated sensors function of the device makes it possible to use sensors, the calibration (correction) coefficients of which are taken into consideration by the device during measurement.

- Using the F1 key, enter the Configuration menu.
- Select the **Calibrated Sensors** function, followed by one of the 5 available sensors.

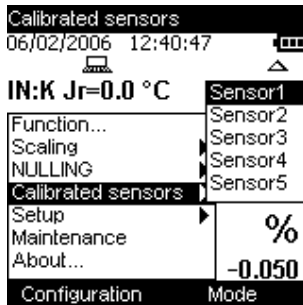

- Confirm (**VAL** key).

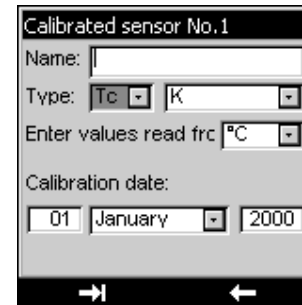

- Enter the sensor information fields. Use the F1 function key (→) to move from one field to the next.

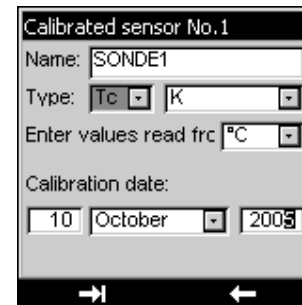

- Confirm your choice using the **VAL** key.

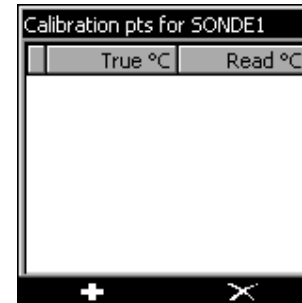

- To add a value in the table of calibration points, use the **+** keys, enter the calibration points (real value and value read) then confirm using the VAL key.
- Repeat this operation for all the calibration points (maximum of 4).

Calibration pts for SONDE1		
	True °C	Read °C
1	-40.00	-39.90
2	0.00	0.02
3	240.00	240.10
4	400.00	399.90

To delete a line, select it then use the key.
 To edit a line, select it then use the navigation key (→) to make editing possible.

- Confirm using the **VAL** key to return to the measurement screen.

To ensure the measurements are made using the calibration coefficients defined earlier, go to the **configuration/function** menu.

- In the **thermocouple** field, select sensor1 (SONDE1-SENSOR1 below).

MEASUREMENT CONFIG.

Function: Tc

TC type: *SONDE1

Display unit: °C

CSF: OFF

Note: the Calibrated sensors are at the top of the list and their name is preceded by an *.

- Confirm the latter using the **VAL** key.

The chosen calibrated sensor is displayed in the measurement screen.

MEASURE

06/02/2006 12:44:03

IN:*SONDE1 Jr=0.0 °C

-0.05

°C

-0.10 -0.07 -0.05

Configuration Mode

Name of calibrated sensor used

D.4 Storage of acquisitions in progress.

The TM630 is designed to store 10,000 values in one or more acquisition bursts.

- Using the F2 key, enter the Mode menu.
- Select the **Memory** function.
- Confirm using the **VAL** key.

Save current measurement

06/02/2006 12:45:22

IN:Pt100

- Save measurement
- Run
- Trigger
- Stop
- Parameters...
- Display burst
- Save burst
- Open burst...
- New free burst
- Burst management...
- Statistics...

Configuration Mode

The drop-down list displays the following functions:

Save MEASUREMENT:

Enable the triggering of an acquisition on a case-by-case basis.

If an acquisition has already been opened, then the following screen is displayed:

MEASURE

06/02/2006 12:45:22

IN:K Jr=0.0 °C

Warning

Do you want to save the measurement burst currently in memory?

°C

-0.05 -0.05 -0.05

No Yes

If you wish to save it, press the F2 key (YES) to confirm.

- You are then requested to enter the name of a file. Using the navigation keys (↑ and ↓), scroll down the letters.
- Using the navigation keys (← and →), move the cursor by one position.
- Using the F2 key () , you can delete the characters entered

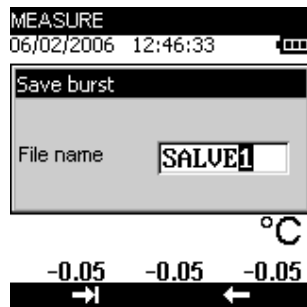

- Once you have entered the file name, confirm by pressing the **VAL** key.

RUN:

Launches the storage of data following the parameters set in the "parameters" function. The pictogram is displayed on the measurement screen

STOP:

Stops the storage in progress.

PARAMETERS:

Allows you to define:

- the size of the acquisition (max 10,000 values),
- the sampling period from 0.5 S to 30 Min,
- and the type of trigger (None, low level, high level).

If you have selected a low level or high level trigger, you must define the trigger level and the number of data to record after this trigger (Post-trigger).

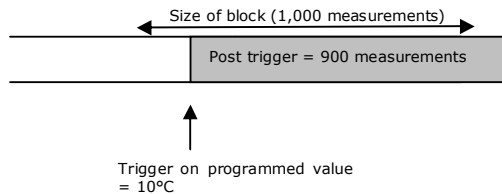
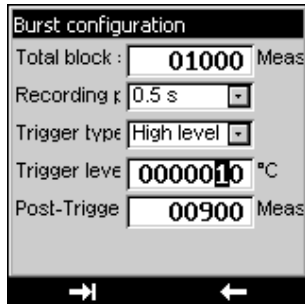

Display burst:

You can display the burst in the form of a table of values or a trend curve.

Burst 'SALVE':
Start date: --/--/---- 16:12:36

N°	Time	°C
1»	00:00:00.0	21.45
2	00:00:00.9	21.84
3	00:00:01.7	22.75
4	00:00:02.9	23.39
5	00:00:03.8	23.97
6	00:00:04.7	24.49
7	00:00:05.5	24.94
1»	...	

- At this level, it is possible to
 - display the trend curve entirely: press the F1 key (GRAPH).

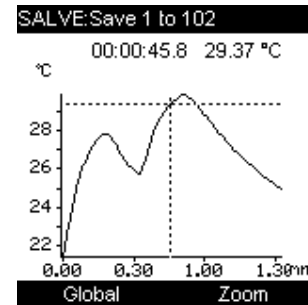

- or place markers so as to display in the form of a graph all the values included between these 2 markers. To do so, press the F2 key (...).

Burst 'SALVE':
Start date: --/--/---- 16:12:36

N°	Time	°C
1»	00:00:09.3	26.38
12	00:00:10.2	26.62
13	00:00:11.1	26.83
14	00:00:12.0	27.02
15	00:00:12.8	27.19
16	00:00:13.7	27.35
17	00:00:14.6	27.53
1»	...	

- Using the navigation keys (↑ and ↓), move the cursor to the value to be marked "value 1" and press the F1 key (1>>).
- For the second marker, press the F2 key (...) and using the navigation keys (↑ and ↓), move the cursor to the value to be marked "value 2" and press the F1 key (2>>).

Burst 'SALVE':		
Start date: --/--/---- 16:12:36		
N°	Time	°C
1»	00:00:07.3	25.70
10	00:00:08.2	26.12
11	00:00:09.3	26.38
12	00:00:10.2	26.62
13	00:00:11.1	26.83
14	00:00:12.0	27.02
15	00:00:12.8	27.19
1»	...	

Burst 'SALVE':		
Start date: --/--/---- 16:12:36		
N°	Time	°C
14	00:00:12.0	27.02
15	00:00:12.8	27.19
16	00:00:13.7	27.35
17	00:00:14.6	27.53
18	00:00:15.8	27.66
19	00:00:16.6	27.77
2»	00:00:17.5	27.82
2»	...	

In this particular example, the graph will display values included between positions 10 and 20.

- Press the F2 key twice (...), to reach the **GRAPH** function, then press F1 to confirm.

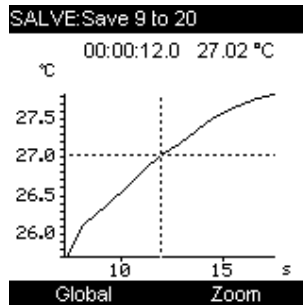

At this level, you can display the whole curve or a zoom around the cursor. The cursor is moved using the navigation keys (← and →).

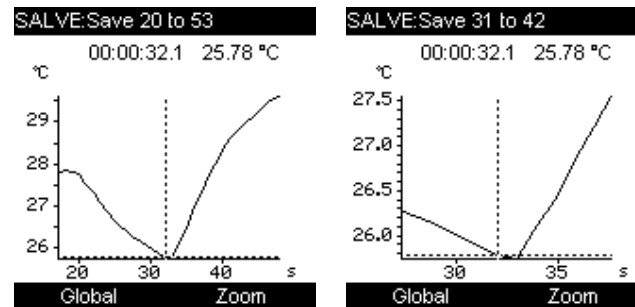
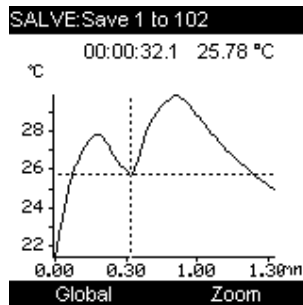

- Press **CLEAR** to return to the table of values.
At this level, you can find out some statistics on the measurements made (Minimum, Maximum, Average and Standard Deviation).

- Press the F2 key three times (...) followed by the F1 key (STAT).

Burst 'SALVE':		
Statistics for measurements 1 to		
N°		°C
1	Min:	21.45
57	Max:	29.86
	Avg.:	27.0829
	Ect	1.72111
Measurements		

- Press F2 (measurements) to return to the table of values.
- Press **CLEAR** to quit the storage function.

Record burst:

This function makes it possible to record the burst in the memory.

- You are then requested to enter the name of a file. Using the navigation keys (↑ and ↓), scroll down the letters.
- Using the navigation keys (← and →), move the cursor by one position.
- Using the F2 key (←), you can delete the characters entered

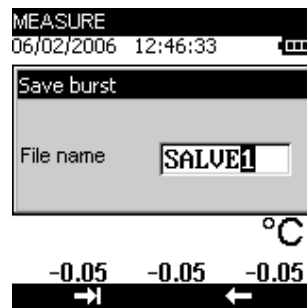

- Once you have entered the file name, confirm by pressing the **VAL** key.

Open burst:

Allows you to choose a specific burst from the list and to open it to display the values. At this level, you can obtain information on the acquisition burst, such as the number of measurements, the date of acquisition, the sensor used, etc.

New free burst:

Allows you to start a new acquisition burst. If a burst is under way, you will be requested to save it.

Burst management:

Allows you to display all the bursts recorded. At this level, you can delete one or all bursts.

Statistics:

Allows you to find out the number of bursts recorded, the number of bytes free as well as the number of measurements that can be recorded.

E. PARAMETER SETTINGS

E.1 Contrast adjustment

In the CONFIGURATION/SETUP menu, you can adjust the display contrast.

- Access this menu using the F1 key.
- Select the **Setup** field using the navigation keys (↑ and ↓), then confirm.
- Select the **Contrast** field using the navigation keys (↑ and ↓), then confirm.
- Using the navigation keys (← and →), modify the contrast as required.

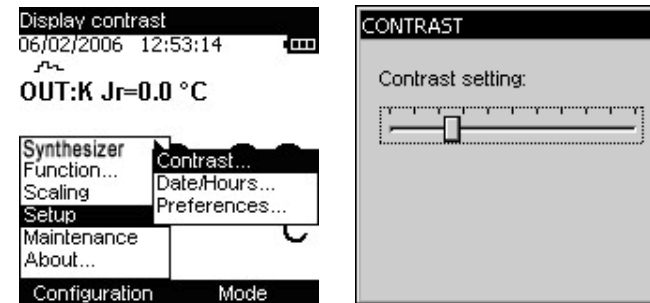

E.2 Date and time setting

In the CONFIGURATION/SETUP menu, you can set the time and date.

- Access this menu using the F1 key.
- Select the **Setup** field using the navigation keys (↑ and ↓), then confirm.
- Select the **Date/Time** field using the navigation keys (↑ and ↓), then confirm.

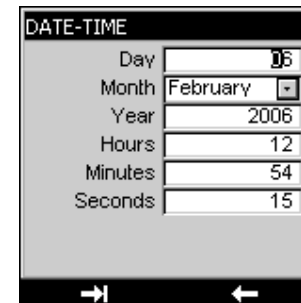

- Use the navigation keys (↑ and ↓) to modify the various parameters.
- Use the navigation keys (← and →) to go to the next field.
- Press **VAL** to confirm.

E.3 "Preferences" setting.

E.3.1 Filtering setting.

In the event of noisy measurements, you can filter the latter to make the value displayed on the screen more stable.

- Access this menu using the **F1** key (configuration menu).
- Select the **Setup** field using the navigation keys (↑ and ↓), then confirm.
- Select the **Preferences** field using the navigation keys (↑ and ↓), then confirm.
- Select the **Filtering** field by pressing the F1 key.
- Four filtering values are available (OFF, 0.5s, 1s and 2s). Select these values using the navigation keys (↑ and ↓).
- Confirm by pressing the VAL key.

E.3.2 Display resolution setting.

In the **CONFIGURATION/SETUP/PREFERENCE** menu, you can select the desired display resolution:

- Access this menu using the **F1** key.
- Select the **Setup** field using the navigation keys (↑ and ↓), then confirm.
- Select the **Preferences** field using the navigation keys (↑ and ↓), then confirm.
- Select the **Resolution** field by pressing the F1 key.

Three types of resolution are available: high (res=1μV), medium (res=10μV) and low (res=100μV).

- Select this resolution using the navigation keys (↑ and ↓).
- Confirm by pressing the VAL key.

E.3.3 Backlight duration setting.

In the same menu (**CONFIGURATION/SETUP/PREFERENCE**), you can control the duration of the backlight (manual, 10s or 1min). Press the **ON/OFF** key briefly to turn on the backlight for the selected duration (10s or 1min). Press it again briefly to start the timing or to turn off the backlight when in **manual** mode.

- Access this menu using the **F1** key.
- Select the **Setup** field using the navigation keys (↑ and ↓), then confirm.
- Select the **Preferences** field using the navigation keys (↑ and ↓), then confirm.
- Select the **Lighting** field by pressing the F1 key.
- Choose the manual or timed mode using the navigation keys (↑ and ↓).
- Confirm by pressing the VAL key.

E.3.4 "Key beeping" setting.

In the **CONFIGURATION/SETUP/PREFERENCE** menu, you can emit a beeping sound every time a key is pressed:

- Access this menu using the F1 key.
- Select the **Setup** field using the navigation keys (↑ and ↓), then confirm.
- Select the **Preferences** field using the navigation keys (↑ and ↓), then confirm.
- Select the **Key Beeping** field using the F1 key.
- Using the navigation keys (↑ and ↓), select the **ON** or **OFF** mode then confirm by pressing the VAL key (if the parameter settings are completed or go to the next field using the F1 key).

E.3.5 Language setting

In the **CONFIGURATION/SETUP/PREFERENCES** menu, the interface language can be selected from English, French, German, Italian or Spanish.

- Access this menu using the F1 key.
- Select the **Setup** field using the navigation keys (↑ and ↓), then confirm.
- Select the **Preferences** field using the navigation keys (↑ and ↓), then confirm.
- Select the **LANGUAGE** field using the F1 key.
- Using the navigation keys (↑ and ↓), select your desired language then confirm by pressing the VAL key (if the parameter settings are completed or go to the next field using the F1 key).

E.3.6 Temperature unit setting

In the **CONFIGURATION/SETUP/PREFERENCES** menu, you can choose the temperature unit that will be displayed.

- Access this menu using the F1 key.
- Select the **Setup** field using the navigation keys (↑ and ↓), then confirm.
- Select the **Preferences** field using the navigation keys (↑ and ↓), then confirm.
- Select the **TEMP unit** field using the F1 key.
- Using the navigation keys (↑ and ↓), select the desired unit then confirm by pressing the VAL key.

E.4 "Maintenance" menu

As part of the follow-up on measurement quality, the user may be asked to perform a regular check of the performance levels.

This check must take into consideration the customary measurement precautions. The following instructions should be followed.

Any handling operations should be performed in the following reference conditions:

- Temperature of the room: 23°C ± 1°C.
- Relative humidity: 45 % to 75 %.

Following this check, should the user find that one or more characteristics of the device are outside the tolerances specified in chapter **G**, said user may:

- Either proceed with the appropriate adjustment, according to the following procedure, which requires equipment which features at least the same performance levels as the one used for the previous check.
- Or return the device to the following address for checking and adjustment.

If service or re-certification of your instrument is needed, please contact us via phone, fax or e-mail, for a Return Material Authorization (RMA) number.

If the unit is to be returned, it is preferable to use the original packaging and return with transportation charges prepaid.

Wahl Instruments, Inc.

234 Old Weaverville Road

Asheville, NC 28804-1228

Phone: 828-658-3131

Fax : 828-658-0728

Email : rma@palmerwahl.com

E.4.1 Adjustment from the Maintenance menu

The TM630 may be adjusted using an instrument with a precision of more than 50 ppm. To adjust the device, go to the **Configuration\Maintenance** menu, enter the password 9456 and then press the **VAL** key.

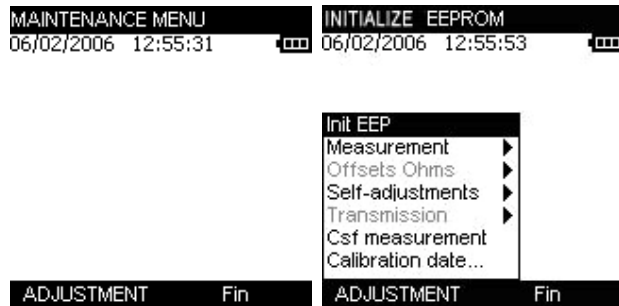

Using the **F1** function key, open the menu to access the following functions:

- Init EEP:**
Allows you to initialize part of the EEPROM (Calibrated Sensors Coefficient)
- Measurement:**
Allows you to access the gauge adjustment function (stated as 100 mV).

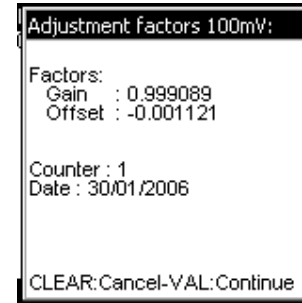

The 1st screen indicates the gain and offset correction value found for the adjustment of this gauge. The counter indicates the number of adjustments the device has undergone with the date of the last adjustment.

- To perform an adjustment:
- Press the **VAL** key.

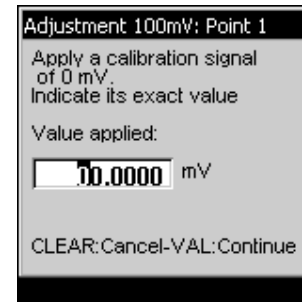

The adjustment is performed in 2 points, around 0V and 100 mV. Apply the calibration signal every time it is requested, and enter the value of this calibration signal in the "Value Applied" field.

- Confirm each step using the **VAL** key.

Measurement CSF:
This function allows you to adjust the Cold Junction Compensation (CSF). You need to know precisely what the temperature of the reference thermocouple used is, and the latter must be a type K thermocouple.

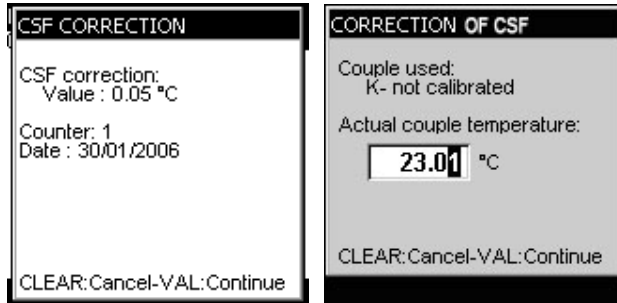

Calibration date:

Should the device undergo calibration, you can enter the date of this calibration and the certificate reference number.



E.5 "About the instrument" menu

In the **Configuration/Setup/About** menu, you can find out:

- The instrument part number
- The Serial number
- The software version
- The name of the company
- The calibration date
- The date of adjustment



F. SOFTWARE UPDATE

The software is updated by the UPG32 program available from Palmer Wahl. To find out which version of the firmware is installed in your unit, use the **Configuration** → **About** menu.

The quickest way to find out if an update is available is to contact Customer Service at Palmer Wahl.

To update the firmware, proceed as follows:

1. If necessary, install on the PC the USB driver for communication with Wahl instruments.
2. Disconnect the leads connected to the measurement and simulation terminals.
3. Connect the instrument to the PC using the USB lead.
4. Download and run the firmware update program.
5. Select the language then the file containing the firmware and download in the first stage.



6. Choose the communication parameters that match the parameters of the TM630. The communication port used is a virtual port which does not correspond to a physical port on your computer. The other parameters to be selected are defined in the diagram below.

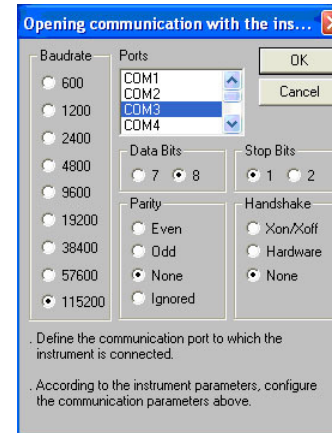

7. Confirm the update by pressing "OK" and wait for the firmware to load into the unit.

G. TECHNICAL SPECIFICATIONS

The precision expressions mentioned herein apply from + 18°C to + 28°C, unless otherwise specified, and are expressed in ± (n % R + C) where R = Reading and C = Constant expressed in practical units, for a confidence interval of 95%.

**They apply to a device positioned in the reference conditions defined below:
Prior power-up of the device for temperature adjustment for 10 minutes
Following a significant thermal shock, it is advisable to allow the device to stabilize its temperature to use the internal reference junction (CSF) with the utmost precision.**

The precision includes the precision of the reference calibrations, the non-linearity, hysteresis, repetitiveness and long-term stability over the time period mentioned.

G.1 Measurement Function

Rated maximum voltage in common mode: 60 VDC or VAC.

G.1.1 Constant voltage

The voltage measurement is made by configuring the device as follows:

Thermocouple: indifferent.
Unit: mV.
CSF: OFF.

Gauge	Scope of measurement	Resolution (min)	Precision / 1year
100 mV	-10 mV to 100mV	1 µV	0.020% R + 3 µV

- Temperature coefficient < 15 ppm R /°C from 0°C to 18°C and from 28°C to 50 °C.
- Rin = 1 M Ω +/- 1%

G.1.2 Temperature by thermocouple.

Type of sensors:
- Standardized in accordance with CEI 584-1/1995 (Thermocouples K, T, J, E, S, B, N).
- In accordance with Din 43710 (thermocouples U and L).
- In accordance with the HOSKINS table (thermocouple C).
- In accordance with the ENGELHARD table (platinum thermocouple).

Sensor	Scope of measurement	Resolution	Precision / 1 year
K	- 250 to - 200°C	0.20°C	0.90°C
	- 200 to - 120°C	0.10°C	0.3°C
	- 120 to - 50°C	0.05°C	0.02 % R + 0.12°C
	-50 to + 1 372°C	0.05°C	0.02 % R + 0.11°C
T	- 250 to - 200°C	0.2°C	0.80°C
	- 200 to - 50°C	0.05°C	0.25°C
	- 50 to + 400°C	0.05°C	0.02 % R + 0.09°C
J	- 210 to - 200°C	0.05°C	0.30°C
	- 200 to - 120°C	0.05°C	0.25°C
	- 120 to + 60°C	0.05°C	0.020 % R + 0.11°C
	+ 60 to + 1 200°C	0.05°C	0.020 % R + 0.09°C
E	- 250 to - 200°C	0.1°C	0.55°C
	- 200 to - 100°C	0.05°C	0.20C
	- 100 to + 450°C	0.05°C	0.020 % R + 0.07°C
	+ 450 to + 1 000°C	0.05°C	0.020 % R + 0.05°C

Sensor	Scope of measurement	Resolution	Precision / 1 year
R	- 50 to + 150°C	0.50°C	0.95°C
	+ 150 to + 550°C	0.20°C	0.40°C
	+ 550 to + 1 768°C	0.10°C	0.020 % R + 0.30°C
S	- 50 to + 150°C	0.5°C	0.85°C
	+ 150 to + 550°C	0.2°C	0.020 % R + 0.4°C
	+ 550 to + 1 768°C	0.1°C	0.020 % R + 0.3°C
B	+ 400 to + 900°C	0.2°C	0.95°C
	+ 900 to + 1 820°C	0.1°C	0.50°C
U	- 200 to - 100°C	0.05°C	0.35°C
	- 100 to + 600°C	0.05°C	0.20°C
L	- 200 to - 100°C	0.05°C	0.30°C
	- 100 to + 900°C	0.05°C	0.20°C
C	- 20 to + 900°C	0.1°C	0.30°C
	+ 900 to + 2 310°C	0.1°C	0.020 % R + 0.15°C
N	- 240 to - 190°C	0.2°C	0.60°C
	- 190 to - 110°C	0.1°C	0.25°C
	- 110 to - 0°C	0.05°C	0.15°C
	+ 0 to + 1 300°C	0.05°C	0.020 % R + 0.07°C
Platinum	- 100 to + 1 400°C	0.05°C	0.3°C
Mo	0 to + 1 375°C	0.05°C	0.020 %R + 0.10°C
NiMo/NiCo	- 50 to + 1 410°C	0.05°C	0.020 %R + 0.35°C

The precision is guaranteed for a reference junction (JR) at 0°C. With the use of the internal JR (except for thermocouple B), add an additional uncertainty of 0.3°C to 0°C. For the other temperatures, it is a good idea to take into consideration the sensitivity of the thermocouple at the temperature (T) considered, namely an additional uncertainty of 0.3°C*(0°C)/S(T).

- Temperature coefficient: < 10 % of precision/°C.
- You can, except for thermocouple B, choose the location of the reference junction by programming it on the keyboard:
 - external at 0°C,
 - internal (temperature compensation at the device terminals).
 - by programming the temperature.

G.1.3 Resistance

The resistance measurement function is obtained by configuring the device as follows:

Sensor: PT100 and Unit: Ohm for the 400 Ohm gauge.
Sensor: PT1000 and Unit: Ohm for the 3600 Ohm gauge.

Gauge	Scope of measurement	Resolution (min)	Precision / 1year
400 Ohm	0 Ω to 400 Ω	10 mΩ	0.012% R + 10 mΩ
3600 Ohm	0 Ω to 3600 Ω	100 mΩ	0.012% R+100 mΩ

Temperature coefficient < 10 ppm R/°C from 0°C to 18°C and from 28°C to 50 °C.

- Automatic wiring diagram detection: 2 wires, 3 wires or 4 wires.
- In the 2-wire assembly, the measurement includes the line resistances.
- In the 3-wire assembly, add the line resistances imbalance.
- Measurement current 0.65mA

G.1.4 Temperature by resistive sensors.

Sensor	Scope of measurement	Resolution	Precision / 1year
Pt 50 (α = 3851)	- 220°C + 850°C	0.01°C	0.012 % R+ 0.06°C
Pt 100 (α = 3851)	- 220°C + 850°C	0.01°C	0.012 % R+ 0.05°C
Pt 100 (α = 3916)	- 200°C + 510°C	0.01°C	0.012 % R+ 0.05°C
Pt 100 (α = 3926)	- 210°C + 850°C	0.01°C	0.012 % R+ 0.05°C

Pt 200 ($\alpha = 3851$)	- 220°C + 1,200°C	0.01°C	0.012 % R+ 0.12°C
Pt 500 ($\alpha = 3851$)	- 220°C + 1,200°C	0.01°C	0.012 % R+ 0.07°C
Pt 1,000 ($\alpha = 3851$)	- 220°C + 760°C	0.01°C	0.012 % R+ 0.05°C
Ni 100 ($\alpha = 618$)	- 60°C + 180°C	0.01°C	0.012 % R+ 0.03°C
Ni 120 ($\alpha = 672$)	- 40°C + 205°C	0.01°C	0.012 % R+ 0.03°C
Ni 1,000 ($\alpha = 618$)	- 60°C + 180°C	0.01°C	0.012 % R+ 0.03°C
Cu 10 ($\alpha = 427$)	- 70°C + 150°C	0.10°C	0.012 % R+ 0.18°C
Cu 50 ($\alpha = 428$)	- 50°C + 150°C	0.01°C	0.012 % R+ 0.06°C

For negative temperatures, use the value displayed R and not its absolute value.

Temperature coefficient: < 10 % of precision/°C.

The above precision is given for a 4-wire connection to the temperature sensor.

You should also take into consideration the actual error of the temperature sensor used, as well as the conditions of its setup.

Measurement current: 0.65 mA