



USER'S MANUAL

TEMPERATURE TRANSMITTERS

LI-24L

LI-24G

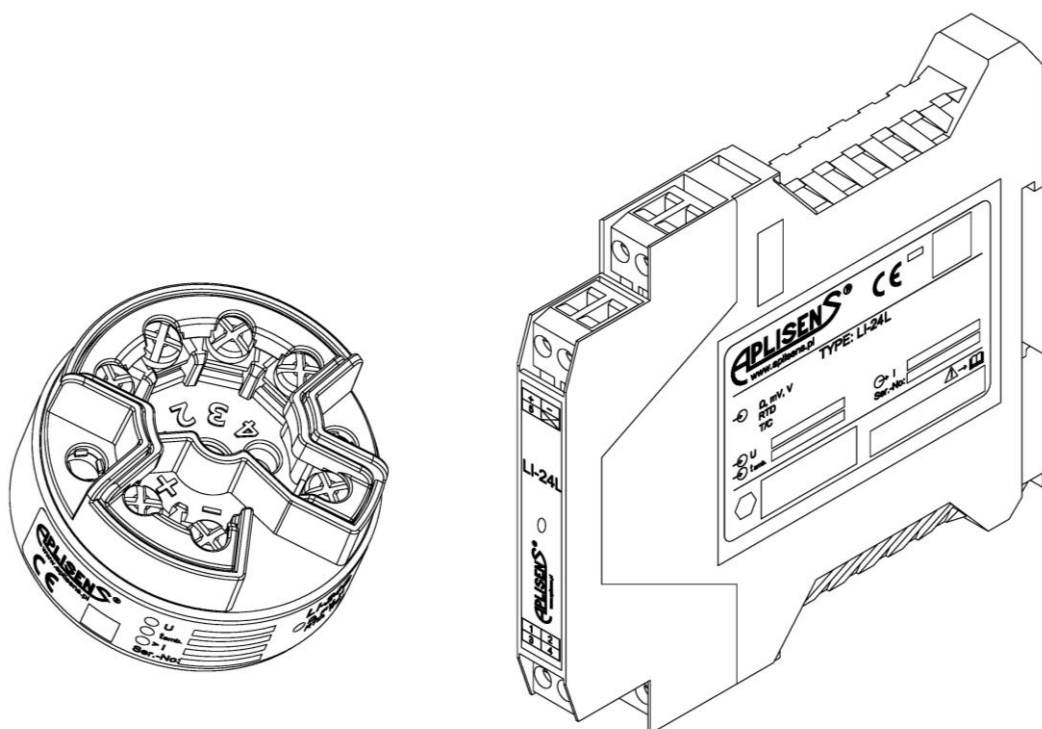

PRODUCT CODE – see (→ [Transmitter identification](#)).

The QR code or ID number identifies the transmitter and provides quick access to the following documentation on the manufacturer's website: user's manual, explosion-proof device user manual, declarations of conformity and copies of certificates.

LI-24L

ID: 0024 0009 0008 0000 0000 0000 0001 05

ID: 0024 0013 0010 0000 0000 0000 0001 25

www.aplisens.pl/ID/00240009000800000000000000000105/

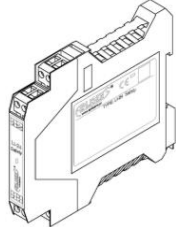

LI-24L (Exi)

ID: 0024 0009 0008 0000 0000 0000 0001 0001 53

ID: 0024 0013 0010 0000 0000 0000 0001 0001 73

www.aplisens.pl/ID/002400090008000000000000000001000153/

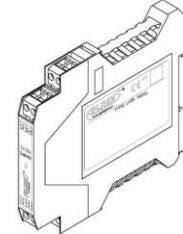

LI-24G

ID: 0025 0010 0008 0000 0000 0000 0001 68

ID: 0025 0014 0010 0000 0000 0000 0001 88

www.aplisens.pl/ID/00250010000800000000000000000168/



LI-24G (Exi)





ID: 0025 0010 0008 0000 0000 0000 0001 0001 19

ID: 0025 0014 0010 0000 0000 0000 0001 0001 39

www.aplisens.pl/ID/002500100008000000000000000001000119/



Symbols used

Symbol	Description
	Warning to proceed strictly in accordance with the information contained in the documentation in order to ensure the safety and full functionality of the device.
	Information particularly useful during installation and operation of the device.
	Information particularly useful during installation and operation of an Ex type device.
	Information on disposal of used equipment.

BASIC REQUIREMENTS AND SAFE USE



The manufacturer will not be liable for damage resulting from incorrect installation, failure to maintain a suitable technical condition of the device or use of the device other than for its intended purpose.

Installation should be carried out by qualified staff having the required authorizations to install electrical and I&C equipment. The installer is responsible for performing the installation in accordance with manual as well as with the electromagnetic compatibility and safety regulations and standards applicable to the type of installation.

All safety and protection requirements must be observed during installation, operation and inspections.

If a malfunction occurs, the device should be disconnected and handed over to the manufacturer for repair.



In order to minimize the risk of malfunction and associated risks to staff, the device is not to be installed or used in particularly unfavourable conditions, where the following hazards occur:

- possible mechanical impacts, excessive shocks and vibration;
- excessive temperature fluctuation;
- water vapour condensation, dusting, icing.

Changes made to the manufacturing of products may be introduced before the paper version of the manual is updated. The up-to-date manuals are available on the manufacturer's website: www.aplisens.com.

TABLE OF CONTENTS

1. INTRODUCTION	6
1.1. Purpose of the document	6
1.2. Registered trademarks	6
1.3. Definitions and abbreviations	7
1.4. Transmitter set range	8
2. SAFETY	9
3. TRANSPORT AND STORAGE	10
3.1. Delivery check	10
3.2. Transport	10
3.3. Storage	10
4. GUARANTEE	10
5. IDENTIFICATION	11
5.1. Manufacturer's address	11
5.2. Transmitter identification	11
5.3. CE mark, declaration of conformity	11
6. INSTALLATION	12
6.1. General recommendations	12
6.1.1. Installation of rail-mounted transmitter LI-24L on a DIN rail	12
6.1.2. Installation of head-mounted transmitter LI-24G in the housing	13
7. ELECTRICAL CONNECTION	15
7.1. Cable connection to transmitter terminals	15
7.1.1. Cable connection	15
7.1.2. Options for connecting sensors, potentiometers and voltage sources to the transmitter	16
7.2. Connection of transmitters with the option of using local HART communication	17
7.3. Transmitter power supply	18
7.3.1. Transmitter supply voltage	18
7.3.2. Specifications of electrical switching terminals	18
7.3.3. Resistance load in power supply line	18
7.3.4. Shielding, equipotential bonding	19
7.4. Final inspection of cabling	19
8. START-UP	19
8.1. Alarm configuration	19
8.2. Configuration of the operating mode	22
8.3. Metrological parameters, types of sensors, measuring ranges and errors	22
9. OPERATION	26
9.1. Operating temperature	26
9.2. Remote configuration of setpoints (HART 5)	26
9.2.1. Compatible devices	26
9.2.2. Compatible configuration software	26
9.2.3. Method of connecting communication devices	26
10. MAINTENANCE	27
10.1. Periodic inspections	27

10.2. Non-periodic inspections	27
10.3. Spare parts.....	27
10.4. Repair.....	27
10.5. Returns.....	27
11. SCRAPPING, DISPOSAL	27
12. HISTORY OF REVISIONS.....	27

LIST OF FIGURES

Figure 1. Set range and measurement limits.....	8
Figure 2. Warning plate - protective seal.....	9
Figure 3. Examples of LI-24G transmitter nameplates in standard and Exi version.....	11
Figure 4. Examples of LI-24L transmitter nameplates in standard and Exi version.....	11
Figure 5. LI-24L transmitter installation on a DIN rail.....	12
Figure 6. Installation of the LI-24G transmitter in an example enclosure manufactured by Aplisens.....	13
Figure 7. Fastening screw lock protection in the LI-24G transmitter.....	14
Figure 8. Markings of LI-24L transmitter terminals.....	15
Figure 9. Markings of LI-24G transmitter terminals.....	15
Figure 10. Methods of connecting sensors, potentiometers and voltage sources.....	16
Figure 11. Electrical connection 4...20 mA of HART to transmitters in standard version.....	17
Figure 12. Electrical connection 4...20 mA of HART to transmitters in Exi version.....	17
Figure 13. Set range current, saturation currents, alarm currents in standard mode.....	19
Figure 14. Set range current, saturation currents, alarm currents in NAMUR mode.....	20
Figure 15. LED indicator on the LI-24L transmitter.....	21

LIST OF TABLES

Table 1. Definitions and abbreviations.....	7
Table 2. Permissible transmitter supply voltages.....	18
Table 3. Metrological parameters of RTD sensors.....	23
Table 4. Metrological parameters of thermocouples.....	24
Table 5. Types of measurements, linearization and mathematical operations.....	25

1. INTRODUCTION

1.1. Purpose of the document

The subject of manual are rail-mounted smart temperature transmitters **LI-24L** and head-mounted smart temperature transmitters **LI-24G**, hereinafter referred jointly to as **LI-24L(G)**. The manual applies to the following versions: standard and intrinsically safe Exi.

The manual contains data, tips and general recommendations for safe installation and operation of the transmitters, as well as troubleshooting in case of possible failure.

The manual does not cover explosion protection issues.



The use of the equipment in hazardous zones without appropriate approvals is forbidden. It is mandatory to read EN.IX.LI.24.L.G Explosion-proof Device User Manual, containing important information related to the installation of intrinsically safe version of the transmitters.

1.2. Registered trademarks

HART® is a registered trademark of FieldComm Group.

Windows® is a registered trademark of Microsoft Corporation.

Google Play® is a service registered and managed by Google® Inc.

1.3. Definitions and abbreviations

Table 1. Definitions and abbreviations.

Item no.	Abbr.	Meaning
1	LRV	“Lower Range Value” – the value of the set range expressed in the units of temperature, resistance or voltage corresponding to the current of 4,000 mA, i.e. 0% of the output setpoint. The set range must not exceed limits which depend on the selected measurement type. The minimum width of the set voltage range [(URV-LRV)] is limited by software to 10°C for resistive sensors (10 Ω for resistance measurement) or 50°C for voltage type sensors (50 mV for voltage measurement).
2	URV	“Upper Range Value” — the value of the set range expressed in the units of temperature, resistance or voltages corresponding to the current of 20,000 mA, i.e. 100% of the output setpoint. The set range must not exceed the set range limits which depend on the selected measurement type. The minimum width of the set voltage range [(URV-LRV)] is limited by software to 10°C for resistive sensors (10 Ω for resistance measurement) or 50°C for voltage type sensors (50 mV for voltage measurement).
3	LRL LSL	“Lower Range Limit” or “Lower Sensor Limit” – the lower limit of the set range expressed in the units of temperature, resistance or voltage. Value (URL-LRL) or (USL-LSL) is referred to as the transmitter base range and depends on the selected measurement type.
4	URL USL	“Upper Range Limit” or “Upper Sensor Limit” – the upper limit of the set range expressed in the units of temperature, resistance or voltage. Value (URL-LRL) or (USL-LSL) is referred to as the transmitter base range and depends on the selected measurement type.
5	LPL	“Lower Processing Limit” – the lower limit of digital processing of the measured value. The transmitter digitally processes the measurement below the lower limit of the LRL/LSL set range. When LPL is reached, the transmitter freezes digital value measurement refreshing. Depending on the settings, the diagnostic alarm mode may be enabled. In addition, collective statuses of the transmitter will be set: “Sensor error”, “First Process Variable Calculation Error”, “First Process Variable out of Range” and “Second or Subsequent Process Variables out of Range”. These can be read out in the diagnostic tab via the HART communication.
6	UPL	“Upper Processing Limit” – the upper limit of digital processing of the measured value. The transmitter digitally processes the measurement up to the upper limit of the URL/USL set range. When UPL is reached, the transmitter freezes digital value measurement refreshing. Depending on the settings, the diagnostic alarm mode may be enabled. In addition, collective statuses of the transmitter will be set: “Sensor error”, “First Process Variable Calculation Error”, “First Process Variable out of Range” and “Second or Subsequent Process Variables out of Range”. These can be read out in the diagnostic tab via the HART communication.

1.4. Transmitter set range

The figure below shows the transmitter LRV/URV set range, limits related to the LRL/URL permissible set range, LPL/UPL digital processing range of the A/D measuring transmitter. As standard, current values of 4 mA/20 mA are assigned to LRV/URV points. In order to obtain reverse characteristics, it is possible to reverse the assignment so that the LRV/URV points are assigned to 20 mA/4 mA currents.

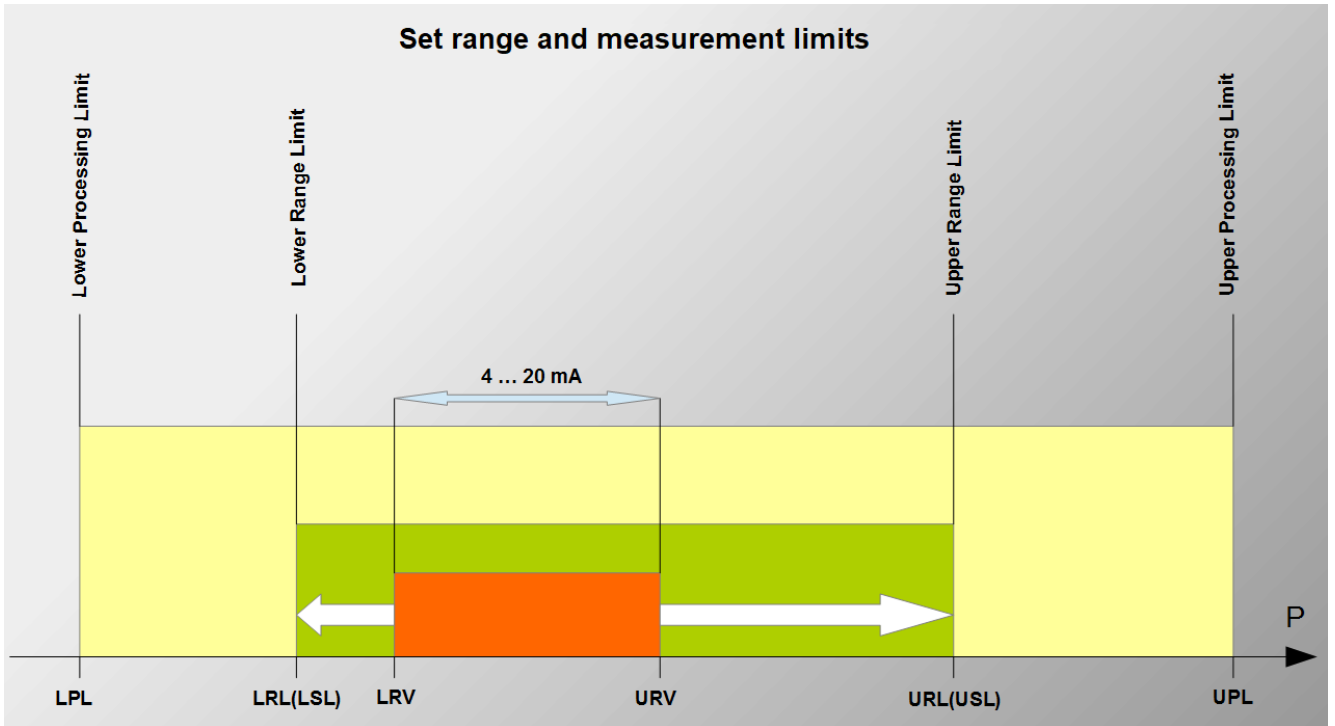

Figure 1. Set range and measurement limits.

2. SAFETY



- The installation and start-up of the device and any activities related to operation shall be carried out after thorough examination of the contents of user's manual and the instructions related thereto;
- installation and maintenance should be carried out by qualified staff having the required authorizations to install electrical and measuring devices;
- the device shall be used according to its intended purpose in line with the permissible parameters specified on the nameplate (→ [Transmitter identification](#));
- the protection elements used by the manufacturer to ensure transmitter safety may be less effective if the device is operated in a manner not consistent with its intended purpose;
- before installing or disassembling the device, it is absolutely necessary to disconnect it from the power source;
- no repairs or alterations to the transmitter electronic system are permitted. Assessment of damages and possible repair may only be performed by the manufacturer or authorized representative;
- do not use instruments if damaged. In case of malfunction, the device must be put out of operation;
- it is not allowed to tear or damage the protective seal on the housing.

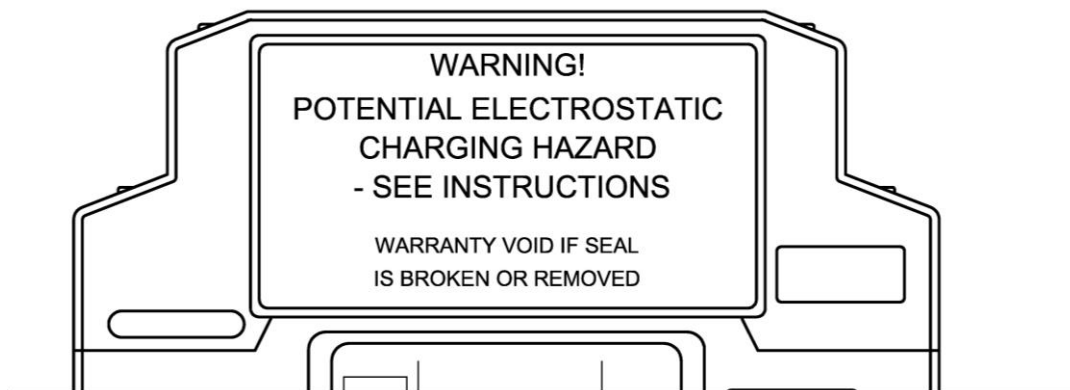

Figure 2. Warning plate - protective seal.

3. TRANSPORT AND STORAGE

3.1. Delivery check

After receiving the delivery of the equipment, it is necessary to:

- make sure that the packaging and its contents were not damaged during transport;
- check the completeness and correctness of the received order, and make sure no parts are missing.

3.2. Transport

Transport of transmitters shall be carried out with the use of covered means of transport, in original packages. The packaging shall be protected against movement and direct impact of atmospheric factors.

3.3. Storage

Transmitters shall be stored in a factory packaging, in a room without vapours and aggressive substances, protected against mechanical impact.

Allowable range of storage temperature:

-40...85°C (-40...185°F).

4. GUARANTEE

General terms and conditions of guarantee are available on the manufacturer's website:

www.aplisens.com/oqolne_warunki_gwarancji



The guarantee shall be repealed if the device is used against its intended use, failure to comply with user's manual or interference with the structure of the device.

5. IDENTIFICATION

5.1. Manufacturer's address

APLISENS S.A.
03-192 Warsaw
Morelowa 7 St
Poland

5.2. Transmitter identification

Depending on the version of the transmitter, the nameplates may differ in the amount of information and parameters.

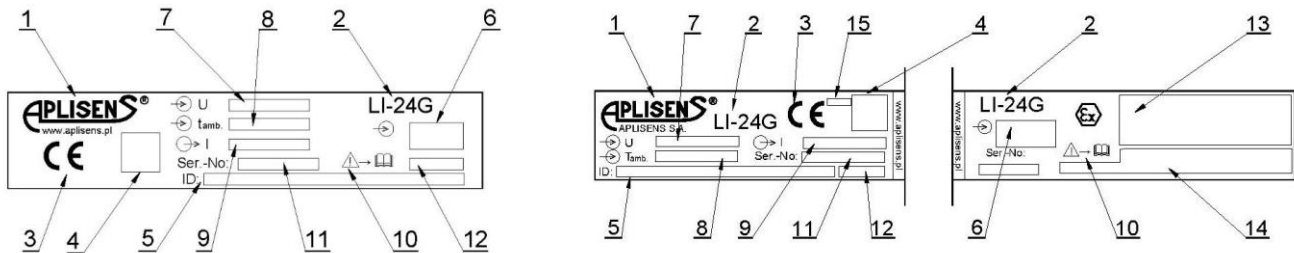

Figure 3. Examples of LI-24G transmitter nameplates in standard and Exi version.

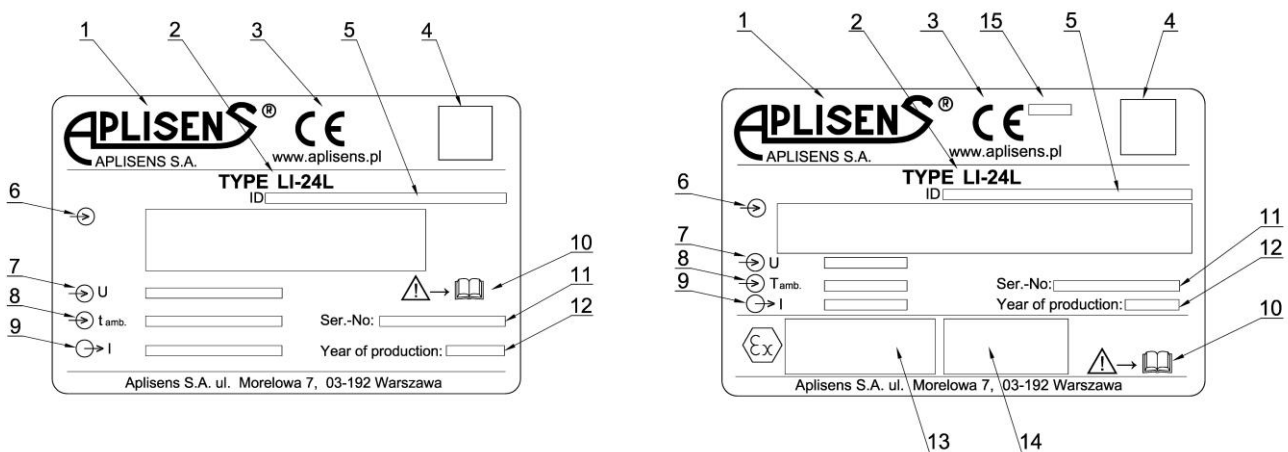

Figure 4. Examples of LI-24L transmitter nameplates in standard and Exi version.

1. Logo and name of the manufacturer.
2. Transmitter type.
3. CE mark.
4. Product QR code.
5. Transmitter model ID.
6. Types of measuring inputs.
7. Supply voltage values.
8. Permissible range of ambient temperature.
9. Output signal.
10. Note about the obligation to read the manual.
11. Transmitter serial number.
12. Year of manufacture.
13. Designation of the explosion-proof type, certificate designation in case of ATEX certified transmitters.
14. Intrinsic safety parameters, i.e.: Ui, li, Pi, Li, Ci, Uo, Io, Po, Co, Lo.
15. Number of the notified body for transmitters with ATEX certificate.

5.3. CE mark, declaration of conformity

The device has been designed to meet the highest safety standards, has been tested and has left the factory in a condition that is safe for operation. The device complies with the applicable standards and regulations listed in the EU Declaration of Conformity and has CE marking on nameplate.

6. INSTALLATION

6.1. General recommendations



It is recommended to install the transmitters in closed enclosures in order to ensure protection against environmental factors.

6.1.1. Installation of rail-mounted transmitter LI-24L on a DIN rail

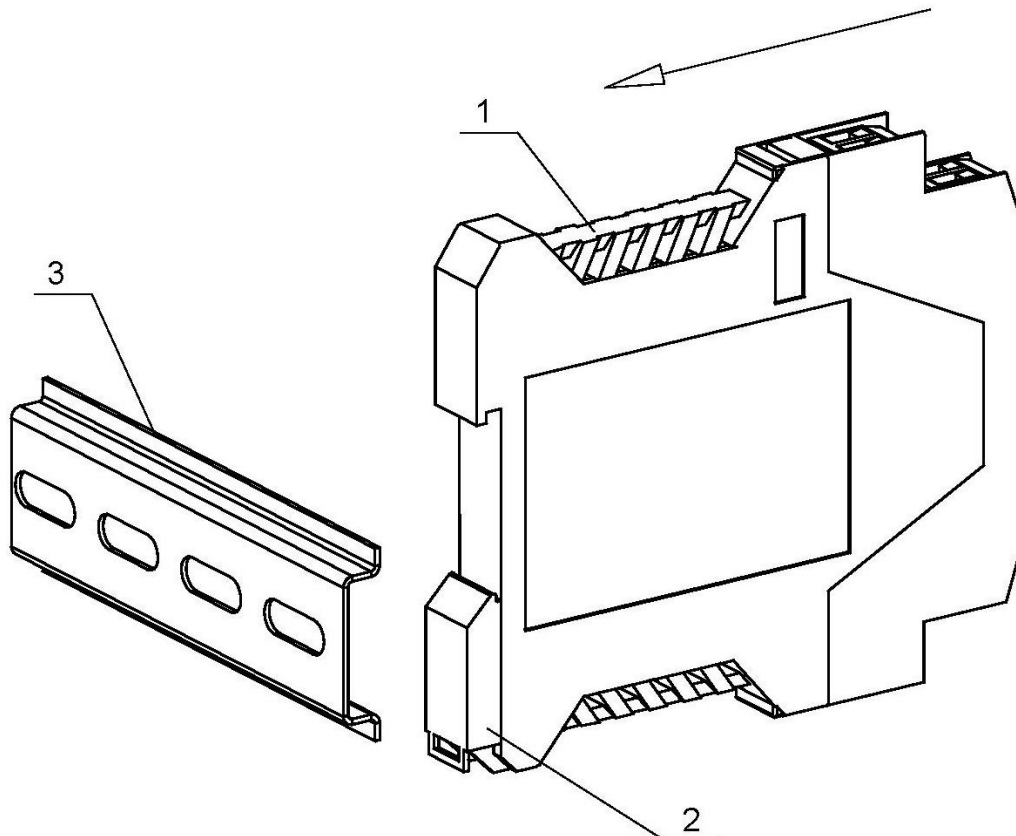
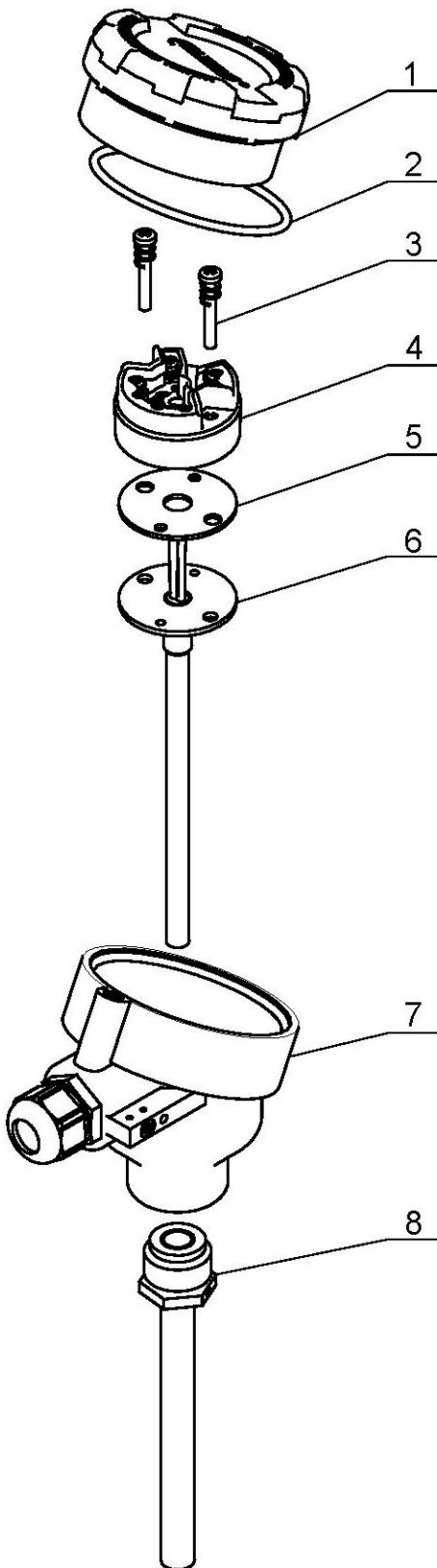

Figure 5. LI-24L transmitter installation on a DIN rail.

1. Rail-mounted transmitter LI-24L.
2. Movable clip.
3. DIN 35 rail.

Insert the movable clip (2) of the LI-24L transmitter housing (1) over the DIN rail (3). Then press the transmitter (1) towards the rail (3). Ensure that the movable clip (2) is clamped on the rail (3). To remove the transmitter, pull the movable clip (2) out with a flat-end screwdriver (put the screwdriver through the clip lug (2)) and slide the transmitter (1) off the rail (3).

6.1.2. Installation of head-mounted transmitter LI-24G in the housing



1. Housing cover.
2. Cover gasket.
3. Fastening screws.
4. Head-mounted transmitter LI-24G.
5. Insulating washer.
6. Measuring unit.
7. Housing.
8. Sensing element protective tube.

Pull the connection cables of the measuring unit (6) through the centre hole of the insulating washer (5) and then through the centre hole of the head-mounted transmitter (4).

Screw the fastening screws with the mounted springs (3) into the transmitter mounting holes (4) and insert them through the holes in the insulating washer (5) and the measuring unit (6).

Mount the head-mounted transmitter (4) together with the insulating washer (5) and the measuring unit (6) to the housing (7) using the fastening screws with mounted springs (3).

Connect the connection cables of the measuring unit (6) to the measuring terminals of the head-mounted transmitter (4) according to section 7 of user's manual.

Unscrew the cable gland, pull the power cable through the cable gland opening into the housing (7). Connect the power supply cables according to section 7.1.1 of user's manual to the power terminals of the head-mounted transmitter (4). Gently pull out the excess cable and tighten the cable gland.

Screw the housing cover (1) together with the gasket (2) onto the housing (7).

Screw in the protective tube of the measuring unit (8).

Figure 6. Installation of the LI-24G transmitter in an example enclosure manufactured by Aplisens.

The head-mounted transmitter LI-24G is equipped with fastening screw lock protection in the form of locks in the mounting holes. The lock is suitable for use with screw threads, and therefore the screws must be screwed into the transmitter housing.



Pushing the fastening screws into the mounting holes instead of screwing them in may damage the screw lock protection.

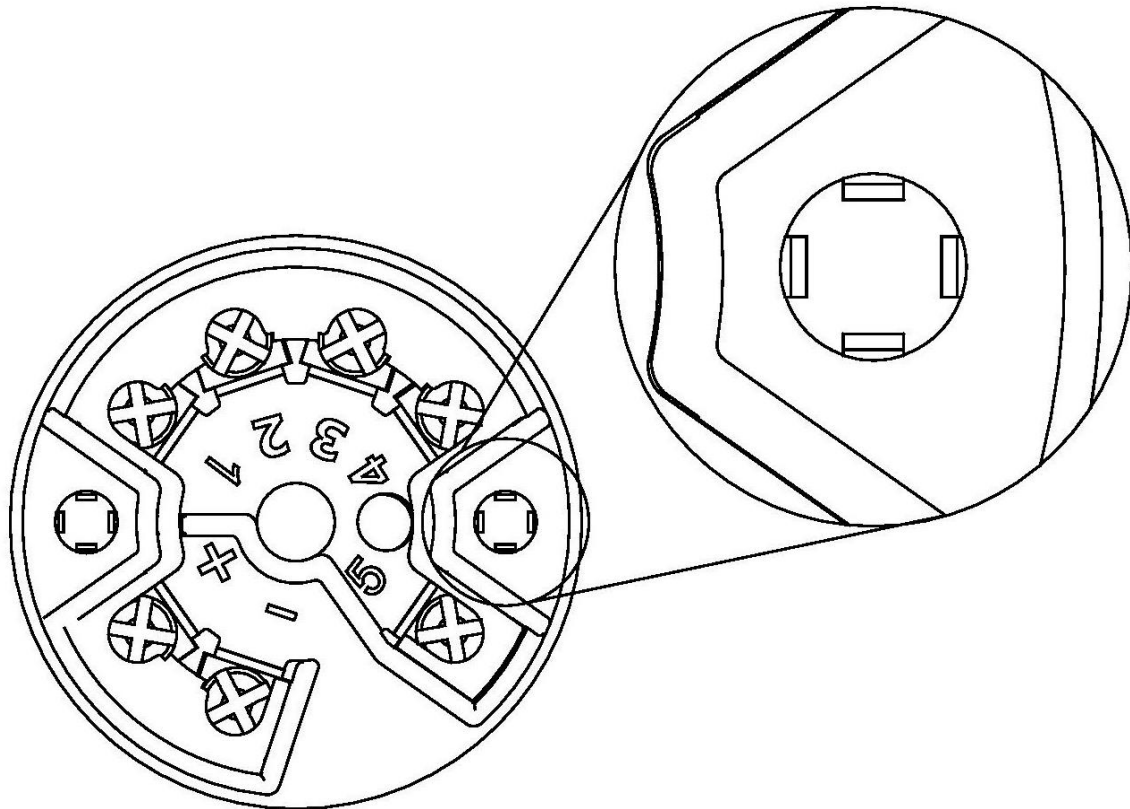

Figure 7. Fastening screw lock protection in the LI-24G transmitter.

7. ELECTRICAL CONNECTION

7.1. Cable connection to transmitter terminals



All connection and installation operations must be performed with disconnected supply voltage and other external voltages, if used.



Failure to provide proper connection of the transmitter may result in danger. Risk of electric shock and/or ignition in potentially explosive atmospheres.

7.1.1. Cable connection

In the LI-24L(G) transmitter, the 4...20 mA current loop power supply and signal cables must be connected to respective “+” and “-” terminals.

In order to perform correct connection of the cables, the following steps shall be performed:

- disconnect power supply of the supply cable line before connecting the transmitter cabling;
- connect the transmitter in accordance with figures below and section → 7.1.2, paying attention to the correct tightening of the screws fixing the conductor core to the terminal;
- depending on the assumed earthing model of the system, attach the cable screen to the bolted terminal of the body ground or cut the excess of the screen and secure with the insulation without connecting to the body ground (applies to LI-24G in housing).



Figure 8. Markings of LI-24L transmitter terminals.

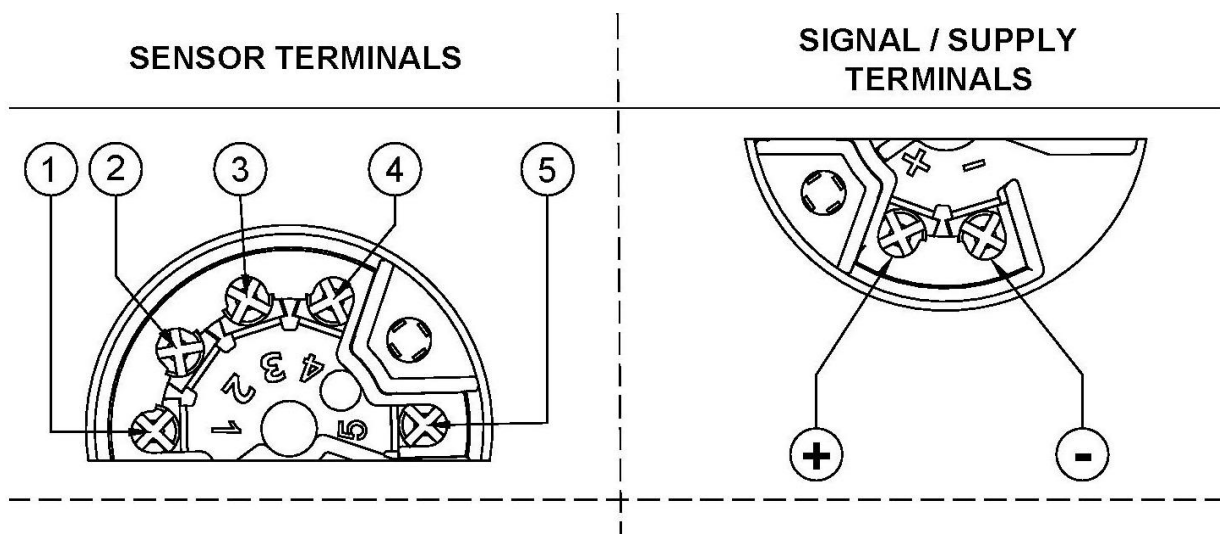

Figure 9. Markings of LI-24G transmitter terminals.

7.1.2. Options for connecting sensors, potentiometers and voltage sources to the transmitter

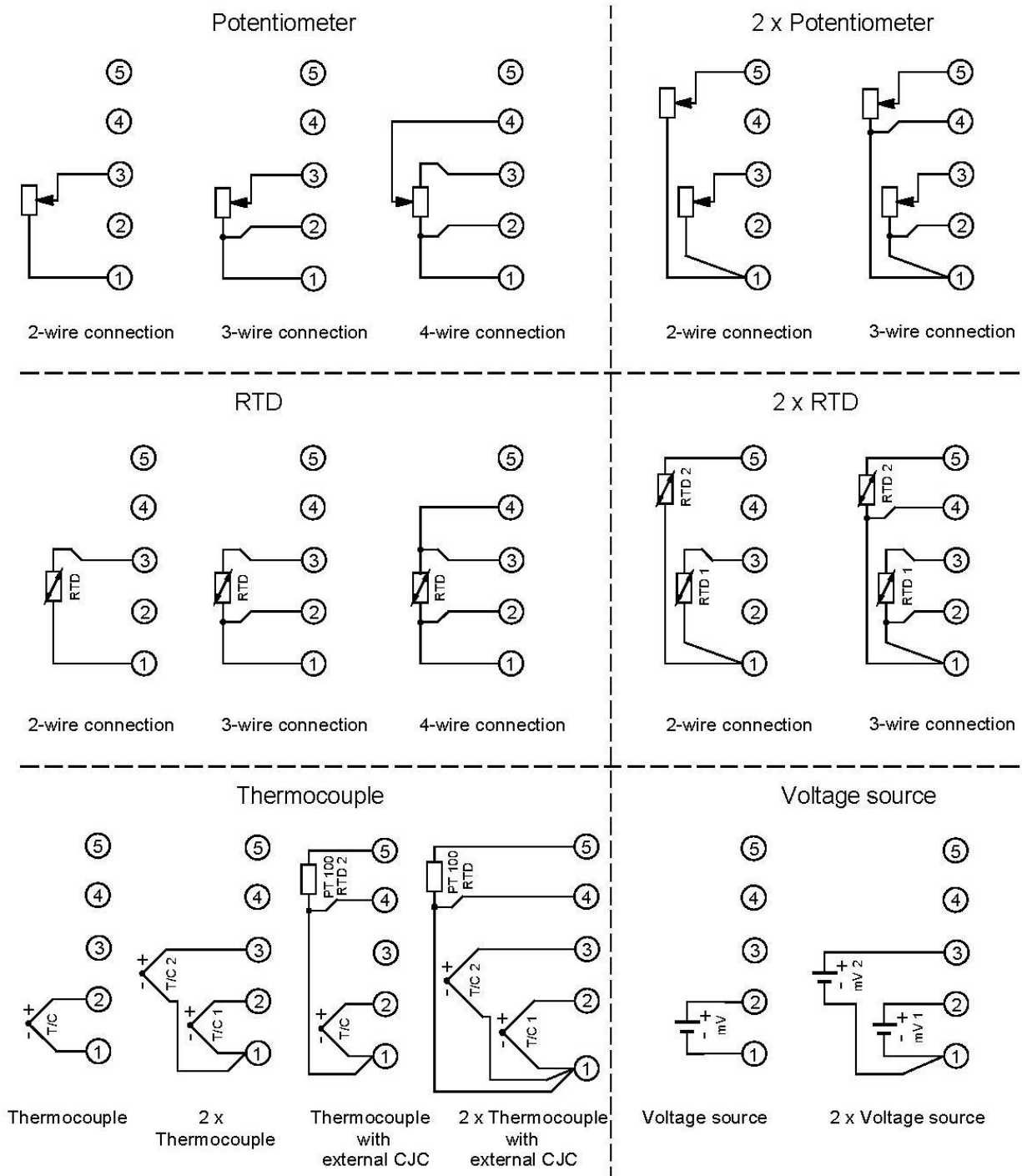

Figure 10. Methods of connecting sensors, potentiometers and voltage sources.

7.2. Connection of transmitters with the option of using local HART communication

The method of connecting a modem to transmitter for local HART communication is shown in the figures below.



In order to communicate using locally connected HART modem to the transmitter "+" and "-" terminals, make sure that the R_o resistance viewed from the side of transmitter terminals towards power source is in the range of $240\ \Omega \leq R_o \leq 1100\ \Omega$.

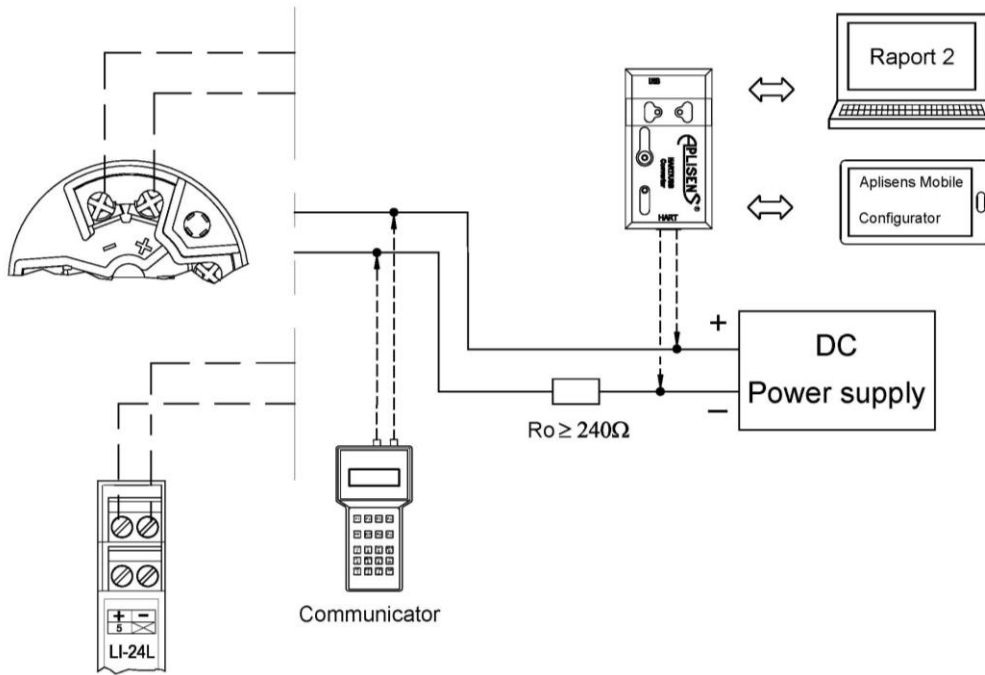

Figure 11. Electrical connection 4...20 mA of HART to transmitters in standard version.

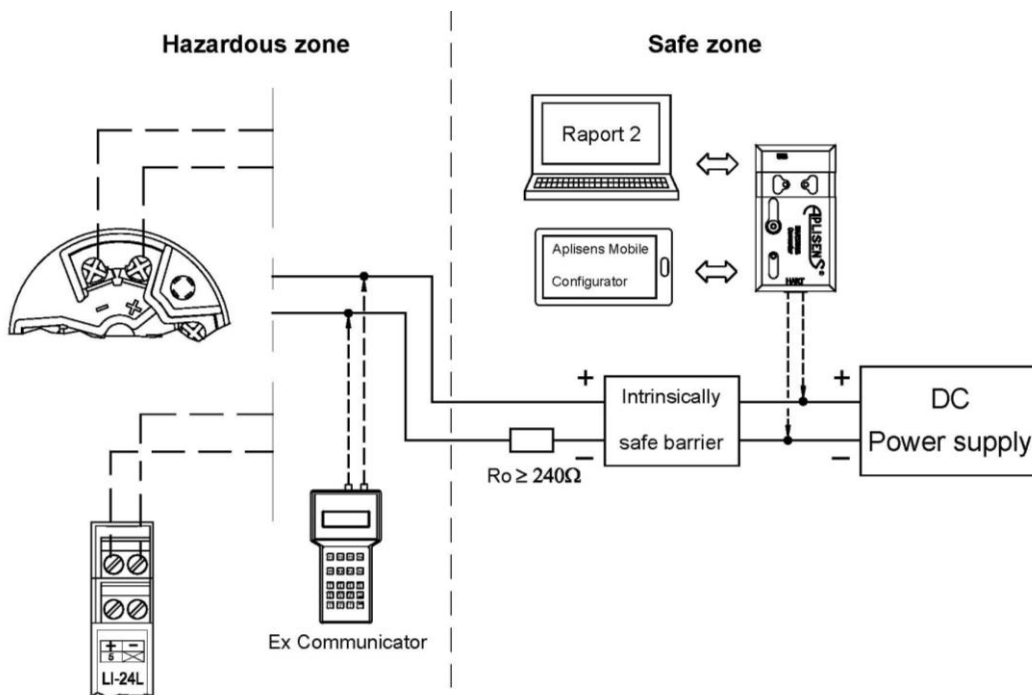

Figure 12. Electrical connection 4...20 mA of HART to transmitters in Exi version.



It is mandatory to read EN.IX.LI.24.L.G Explosion-proof Device User Manual, containing important information related to the installation of transmitters in intrinsically safe version.

The converter may also be operated using **Aplisens Mobile Configurator** installed on smartphones with Android system and connected using wireless communication.

The software is available on Google Play®

<https://play.google.com/store/apps/details?id=com.aplisens.mobile.amc>

7.3. Transmitter power supply

7.3.1. Transmitter supply voltage



Power cables may be live.

In case of incorrect connection there is a risk of electric shock and/or explosion.



Installation of the transmitter in explosion-risk atmospheres must comply with the requirements of relevant instructions and national standards and regulations.

All explosion protection data is given in manual EN.IX.LI.24.L.G.

Table 2. Permissible transmitter supply voltages.

Version	Minimum supply voltage	Maximum supply voltage
Standard	10 V DC	36 V DC
Exi*	10 V DC	30 V DC

*For details on the intrinsically safe version, see manual EN.IX.LI.24.L.G.

7.3.2. Specifications of electrical switching terminals

Electrical switching terminals are suitable for conductors with the cross-section area of:

- for LI-24L: ≤ 2,5 mm²;
- for LI-24G: ≤ 1,75 mm².

Possible cables to be used:

- unshielded when using the analogue signal only;
- shielded, approved for the HART communication;
- shielded on the sensor(s) side for a cable length greater than 30 m.

7.3.3. Resistance load in power supply line

The power line resistance, power source resistance and other additional resistances connected in series increase the voltage drops between the power source and the transmitter terminals. The maximum transmitter current under normal operation conditions may amount to 20,500 mA. However, the power balance should take into account situation where user sets a "Custom" alarm with a maximum value of 23,000 mA.

The maximum resistance value in the power circuit (along with the power cables resistances) is defined by the formula:

$$R_{L_{MAX}} [\Omega] \leq \frac{(U - 10)[V]}{0,02300 [A]}$$

where:

U – voltage at the supply terminals of 4...20 mA current loop [V].

R_{L_MAX} – maximum power line resistance [Ω].

7.3.4. Shielding, equipotential bonding

Optimal protection against interference is provided by the earthing of the screen on both sides (in the cabinet and equipment). In case of potential difference between earthing points of devices which may result in the flow of equipotential currents, the screen shall be earthed on one side.

7.4. Final inspection of cabling

After completing the electrical installation of the transmitter, it is necessary to check the following:

- does the supply voltage measured at the transmitter terminals at maximum set current match the range of supply voltage specified on the transmitter nameplate?
- Is the transmitter connected according to the information given in section ([→ Cable connection to transmitter terminals](#))?
- Are all the screws tightened?
- Are the cable terminals tightened?
- Is the cable gland tightened?

8. START-UP

Upon request, the customer receives a transmitter configured according to the setpoints specified in the order. The current base range and the basic unit of the transmitter can be read out from the device via the HART communication.

8.1. Alarm configuration

The LI-24L(G) transmitter has developed internal diagnostics which monitors the operation of transmitter’s electronic circuits, process and environmental parameters. Diagnosed dangerous conditions or malfunctions of the transmitter internal systems, depending on the settings, may result in enabling alarm current. The user can enable/disable diagnostics. By default, current alarms are disabled. The figures below shows the normal operation ranges of the transmitter process output as well as saturation and alarm current ranges.

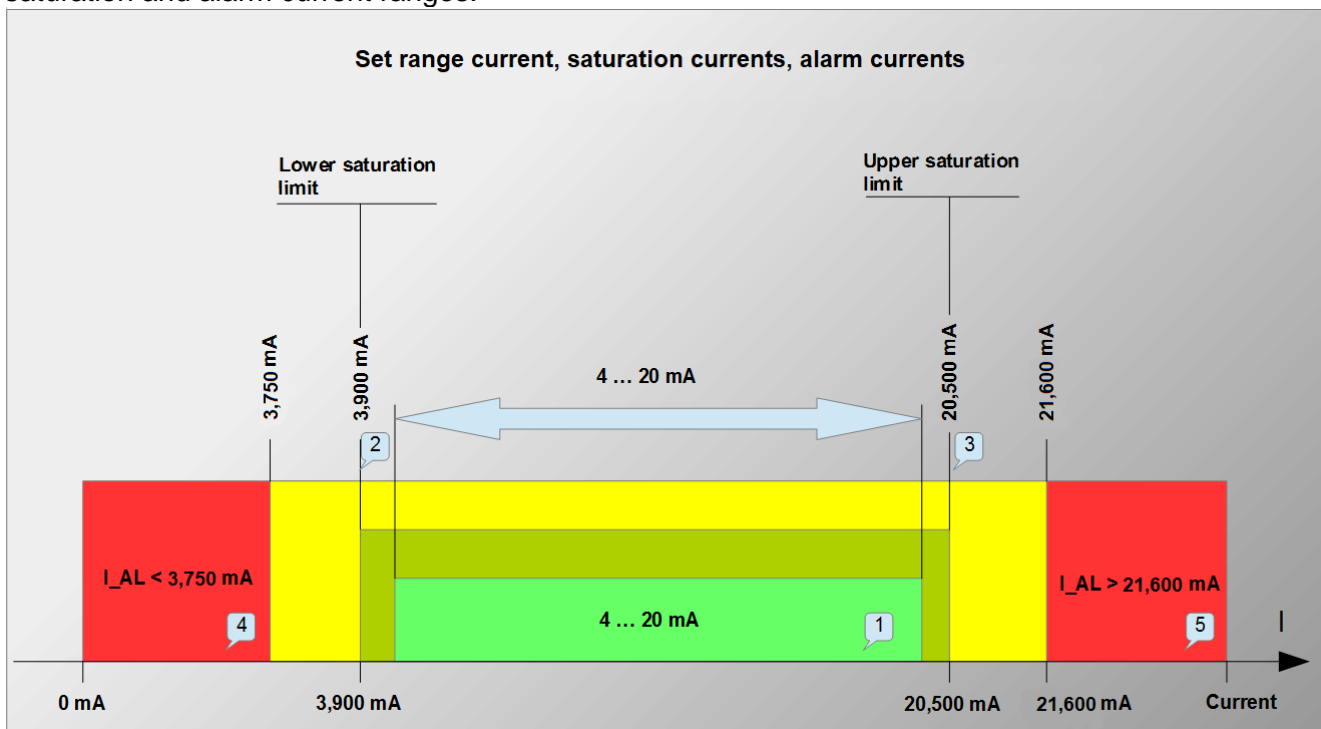

Figure 13. Set range current, saturation currents, alarm currents in standard mode.

- 1 – Set 4...20 mA current area corresponding to setpoint 0...100% of the process output.
- 2 – Lower saturation current of 3,900 mA.

- 3 – Upper saturation current of 20,500 mA.
- 4 – Alarm current area $I_{AL} < 3,750$ mA for internal diagnostic alarms.
- 5 – Alarm current area $I_{AL} > 21,600$ mA for internal diagnostic alarms.

The user can define the value of the alarm current (CUSTOM) in the range from 3,600 mA to 23,000 mA. The CUSTOM mode should be used with caution as it allows setting the alarm condition (constant current value) in the basic working area of the current loop (4...20 mA).

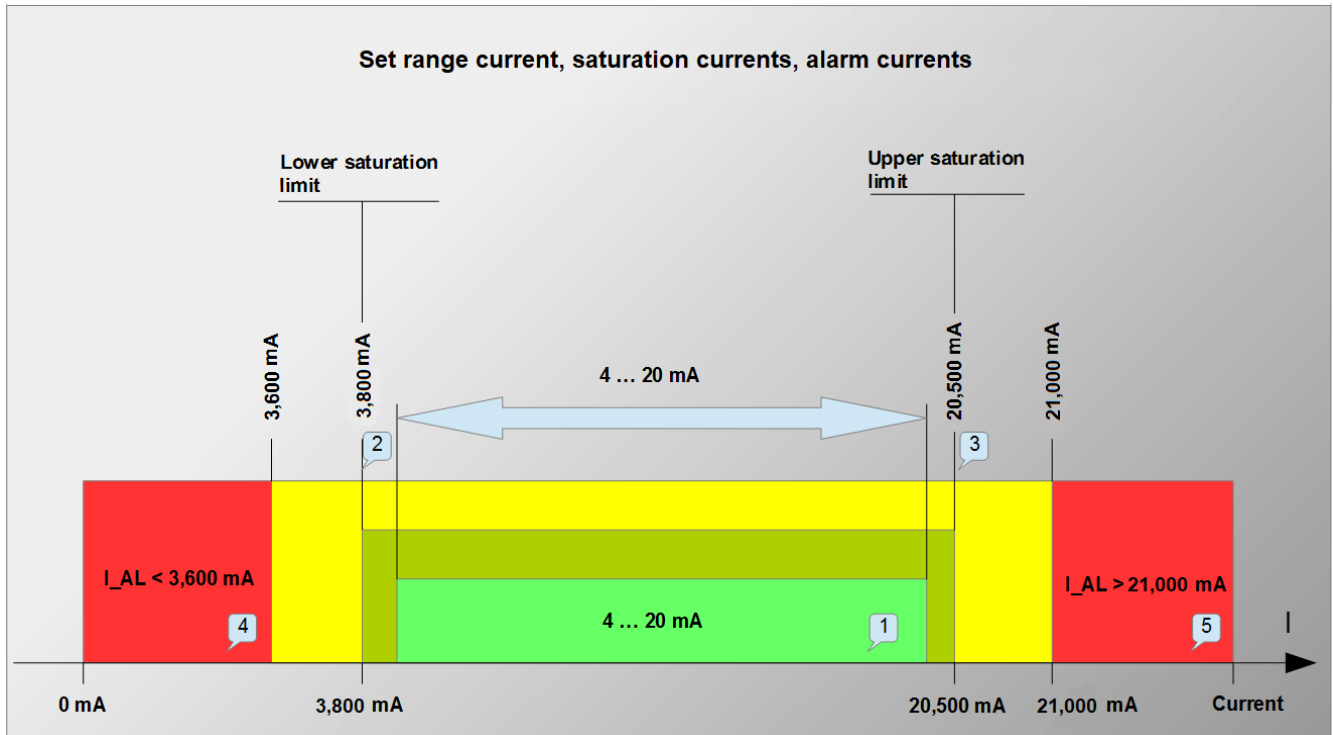

Figure 14. Set range current, saturation currents, alarm currents in NAMUR mode.

- 1 – Set 4...20 mA current area corresponding to setpoint 0...100% of the process output.
- 2 – Lower saturation current of 3,800 mA.
- 3 – Upper saturation current of 20,500 mA.
- 4 – Alarm current area $I_{AL} < 3,600$ mA for internal diagnostic alarms.
- 5 – Alarm current area $I_{AL} > 21,000$ mA for internal diagnostic alarms.



Temperature transmitters LI-24L(G) manufactured by Aplisens meet the alarm requirements Namur NE 89 and Namur NE 43.

The user can define the value of the alarm current (CUSTOM) in the range from 3,600 mA to 23,000 mA. The CUSTOM mode should be used with caution as it allows setting the alarm condition (constant current value) in the basic working area of the current loop (4...20 mA).

The transmitter diagnostics continually tests the environmental parameters:

- temperature of the ADC transducer converting the electric signal from the temperature sensor to the digital value of measurement;
- temperature of the CPU unit (transmitter's main microcontroller). If the transmitter operating temperature limits are exceeded, the diagnostics, depending on the settings, will trigger an alarm current. Temperature return to permissible operating range of the transmitter will result in deactivation of the diagnostic alarm mode and restoration of normal operation.

The transmitter diagnostics continually tests the process parameters of temperature:

- if the measured process variable value increases above the upper value of the base range relative to URL, when UPL is reached, the diagnostics, depending on the settings, will trigger

an alarm current. Temperature return below UPL point will result in deactivation of the alarm and restoration of the transmitter to its normal operation;

- if the measured process variable value decreases below the lower value of the base range relative to LRL, when LRL is reached, the diagnostics, depending on the settings, will trigger an alarm current. Temperature return above the LPL point will result in deactivation of the alarm and restoration of the transmitter to its normal operation.

The transmitter diagnostics continually tests electric parameters and software resources of the transmitter:

- if the internal diagnostics detects malfunctions or failures of the transmitter that are not critical for integrity of hardware and software, the transmitter software, depending on the settings, will trigger a current alarm. The diagnostic alarm state will continue until the malfunction or failure is resolved. The LED indicating the operating status of the device will indicate improper operation to attract the operator's attention. The transmitter, depending on the settings, will set the current output to the alarm state;
- if the internal diagnostics detects 20 unauthorised access attempts to write operation or password change protection codes, the transmitter, depending on the settings, will set the current output to alarm state. This state will continue to exist until the transmitter software reset is performed or until power supply is disconnected and then re-connected.

Diagnostics:

- it detects RAM, FLASH, CPU errors and current mismatch in the current loop in alarm mode. The detected errors, depending on the settings, result in an alarm current.

The design of the transmitter allows detection of many dangerous failures. In addition to the diagnostics signalled with alarm current and the diagnostics being readable by via digital HART communication, the LI-24L transmitter is equipped with a two-colour LED indicator which signals the operating status of the device.

Description of displayed prompts:

- green – correct operating status;
- red – hardware failure;
- flashing red – missing sensor, exceeded ambient temperatures, excessive drift of reference voltages;
- LED indicator OFF – disconnected power supply or damage of power supply circuit.

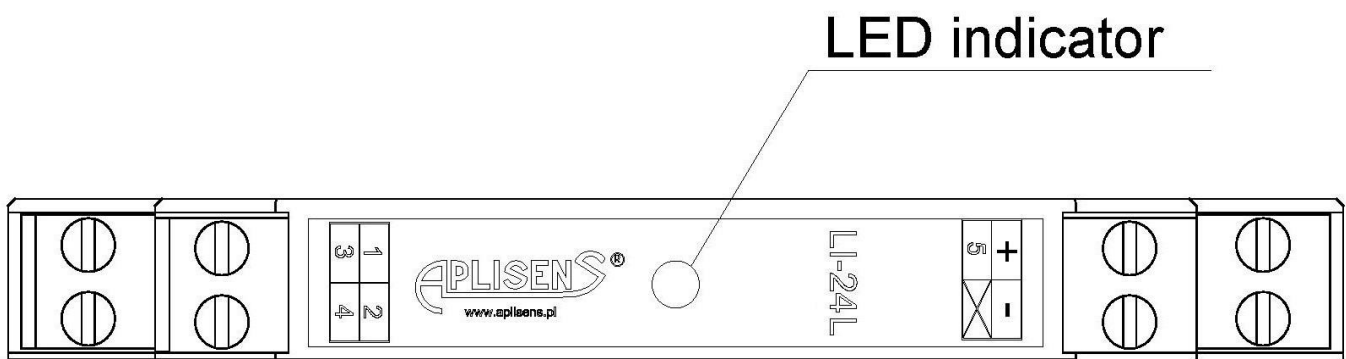

Figure 15. LED indicator on the LI-24L transmitter.

8.2. Configuration of the operating mode

Before starting the work with the transmitter, the following parameters must be configured:

- basic unit of the transmitter process variable;
- measurement input type (voltage/resistance);
- measurement sensor processing characteristics (selection of sensor linearization characteristics);
- measurement sensitivity range (100 mV/1000 mV or 400 Ω /2000 Ω);
- type of sensor connections, number of terminals, CJC configuration (internal, external or none);
- type of the mathematical function processing the signal from two sensors (2 x RTD 2-wire connection, 2 x RTD 3-wire connection, 2 x thermocouple, 2 x thermocouple with external CJC (see → [Figure 10. Methods of connecting sensors, potentiometers and voltage sources.](#))):
 - difference of measurement from channels: Ch1-Ch2 or Ch2-Ch1;
 - measurement average: $0,5 \cdot (Ch1+Ch2)$;
 - measurement average with redundancy: $0,5 \cdot (Ch1+Ch2)$ or Ch2 or Ch1, when one of the sensors is damaged. Redundancy corresponds to the following variants of the sensors connection: 2 x RTD 2-wire connection, 2 x RTD 3-wire connection, 2 x thermocouple, 2 x thermocouple with external CJC (alarm deactivation is required);
 - minimum value of the two measurements: $\min (Ch1, Ch2)$;
 - maximum value of the two measurements: $\max (Ch1, Ch2)$;
- additional parameters such as offset of measuring channels or compensation of sensor lead resistance;
- start point of the set LRV range in the basic unit;
- end point of the set URV range in the basic unit;
- damping time constant;
- analogue output processing characteristic mode;
- transmitter tag (TAG);
- setting of the password for the settings change lock;
- setting of the write lock after performing the configuration actions.

8.3. Metrological parameters, types of sensors, measuring ranges and errors

User's processing characteristics.

Input impedance, thermocouple or voltage input:

>10 M Ω .

Additional error due to supply voltage changes:

$\pm 0,002 \% / V$.

Temperature impact compensation:

50 points at operating temperature range, segmental with linear approximation between points.

Output updates time (calculation cycle):

$0.74 \div 1.8$ s.

Additional electronic damping:

$0 \div 30$ s.

Table 3. Metrological parameters of RTD sensors.

RTD sensor connected with 2, 3 or 4 wires						
Input – RTD						
Thermal resistance sensors		2, 3 or 4 wires connection				
Sensor current		~250 μ A				
Maximum wires resistance		25 Ω				
Sensor type	Standard	Basic range	Min. range span	Processing error Δp	Temperature processing error Δtp	Analogue output error
		[°C]	[°C]	[K]	[K/K]	[%]
1	2	3	4	5	6	7
Pt10 ($\alpha=0.003850$)	PN-EN 60751+A2, IEC751, DIN43760, JISC 1604-97, BS 1904	-200÷850	10	± 0.8	± 0.035	Analogue output error is 0.05% FSO (Full Scale Output) over the operating temperature range.
Pt50 ($\alpha=0.003850$)		-200÷850	10	± 0.2	± 0.0070	
Pt100 ($\alpha=0.003850$)		-200÷850	10	± 0.07	± 0.0035	
Pt200 ($\alpha=0.003850$)		-200÷850	10	± 0.2	± 0.0020	
Pt500 ($\alpha=0.003850$)		-200÷850	10	± 0.05	± 0.0007	
Pt1000 ($\alpha=0.003850$)		-200÷266	10	± 0.03	± 0.0003	
Pt 98 ($\alpha=0.003923$)	SAMA RC-4-1966	-200÷650	10	± 0.07	± 0.0035	
Ni100 (W100=1.617)	PN-83/M-53952	-60÷180	10	± 0.07	± 0.0030	
Cu100 (W100=1.426)		-50÷180	10	± 0.07	± 0.0030	
Pt10 ($\alpha=0.003916$)	JIS C1604-81	-200÷630	10	± 0.8	± 0.035	
Pt50 ($\alpha=0.003916$)		-200÷630	10	± 0.2	± 0.0070	
Pt100 ($\alpha=0.003916$)		-200÷630	10	± 0.07	± 0.0035	
Pt10 (W100=1.3910)	GOST 6651-94	-200÷1100	10	± 0.8	± 0.035	
Pt50 (W100=1.3910)		-200÷1100	10	± 0.2	± 0.0070	
Pt100 (W100=1.3910)		-200÷1100	10	± 0.07	± 0.0035	
Pt500 (W100=1.3910)		-200÷900	10	± 0.05	± 0.00070	
Cu50 (W100=1.426)		-50÷200	10	± 0.2	± 0.0070	
Cu100 (W100=1.426)		-50÷200	10	± 0.07	± 0.0030	
Cu50 (W100=1.428)		-185÷200	10	± 0.2	± 0.0070	
Cu100 (W100=1.428)		-185÷200	10	± 0.07	± 0.0030	
Ni100 (W100=1.617)		-60÷180	10	± 0.07	± 0.0030	
Resistance (resistor, potentiometer)						
		[Ω]	[Ω]	[m Ω]	[m Ω /K]	As above
Measuring range 1		0...400	10	± 30	± 2	
Measuring range 2		0...2000	10	± 120	± 2	
1	2	3	4	5	6	7

Table 4. Metrological parameters of thermocouples.

Input – Thermocouples		Thermocouples				
Input impedance		>10 MΩ				
Maximum wires resistance		500 Ω (wires + thermocouple)				
Cold junctions compensation		internal sensor, external sensor Pt100, temperature constant of the cold junctions				
Sensor type	Standard	Basic range	Min. range span	Processing error Δp	Temperature processing error Δtp	Analogue output error
		[°C]	[°C]	[K]	[K/K]	[%]
1	2	3	4	5	6	7
B (Pt30Rh-Pt6Rh)	PN-EN 60751+A2, IEC584, NIST MN175, DIN43710, BS4937, ANSI MC96.1, JIS C1602, NF C42-321	500+1820	50	±0.55	<±0.001	Analogue output error is 0.05% FSO (Full Scale Output) over the operating temperature range
E (Ni10Cr-Cu45Ni)		-150+1000	50	±0.15	<±0.001	
J (Fe-Cu45Ni)		-210+1200	50	±0.20	<±0.001	
K (Ni10Cr-Ni5)		-150+1372	50	±0.30	<±0.001	
N(Ni14CrSi-NiSi)		-150+1300	50	±0.25	<±0.001	
R(Pt13Rh-Pt)		50+1768	50	±0.35	<±0.001	
S(Pt10Rh-Pt)		50+1768	50	±0.40	<±0.001	
T(Cu-Cu45Ni)	-150+400	50	±0.15	<±0.001		
TC Typ L	GOST P 8.585-2001	-200+800	50	±0.20	<±0.001	
Internal CJC sensor	-	-40+85	-	±[0.35+0.007 (T-273)]	<±0.009	
Voltage						
		[mV]	[mV]	[μV]	[μV/K]	As above
Measuring range 1		-10...100	10	±6	<±0.06	
Measuring range 2		-100...1000	10	±50	<±0.5	
1	2	3	4	5	6	7

ΔG – limiting error [K] or [%]

$$\Delta G [K] = \Delta p [K] + \Delta tp \frac{[K]}{[K]} \cdot TO [K] + TN [K] \cdot \frac{0,05 [%]}{100 [%]}$$

$$\Delta G [%] = \frac{\Delta p [K] \cdot 100 [%]}{TN [K]} + \frac{\Delta tp [K/K] \cdot TO [K] \cdot 100 [%]}{TN [K]} + 0,05 [%]$$

TN [K] – span of the measured temperature set range, algebraical difference between the upper and lower limit of the set range.

TO [K] – span of the transmitter ambient temperature range, algebraical difference between the upper and lower ambient temperatures (accepted as the boundary operating temperatures).

Table 5. Types of measurements, linearization and mathematical operations.

Voltage measurements, TC type sensors. Voltage measurement range 0...100 mV or 0...1000 mV	
Linearization type/base range	Sensor type and CJC configurations
Linear/0...100 mV or 0...1000 mV	1 x TC (voltage measurement);
Customised multi-section linear, 21 points/0...100 mV or 0...1000 mV	2 x TC (voltage measurements);
Type B (IEC 584)/250... 1820 °C	1 x TC (without CJC);
Type E (IEC 584)/-200... 1000 °C	1 x TC (internal CJC – PT100);
Type J (IEC 584)/-210... 1200 °C	1 x TC (external CJC – PT100, 3-wire);
Type K (IEC 584)/-200... 1372 °C	2 x TC (without CJC);
Type N (IEC 584)/-200... 1300 °C	2 x TC (internal CJC – PT100);
Type R (IEC 584)/-20... 1768.1 °C	2 x TC (external CJC – PT100, 3-wire)
Type S (IEC 584)/-30... 1768.1 °C	
Type T (IEC 584)/-200... 400 °C	
Type L (GOST P 8.585-2001)/-200... 800 °C	
Resistance measurements, RTD type sensors. Resistance measurement range 0...400 Ω or 0...2000 Ω	
Linearization type/base range	Sensor type configurations
Linear/0...400 Ω or 0...2000 Ω	1 x RTD 2 x Wire
Custom multi-section linear, 21 points/0...400 Ω or 0...2000 Ω	1 x RTD 3 x Wire
PT10 $\alpha = 0.003850$ (IEC 751)/-200... 850 °C	1 x RTD 4 x Wire
PT10 $\alpha = 0.003916$ (JIS C 1604-81)/-200... 630 °C	2 x RTD 2 x Wire
PT10 W100 = 1.3910 (GOST 6651-94)/-200... 1100 °C	2 x RTD 3 x Wire
PT50 $\alpha = 0.003850$ (IEC 751)/-200... 850 °C	
PT50 $\alpha = 0.003916$ (JIS C 1604-81)/-200... 630 °C	
PT50 W100 = 1.3910 (GOST 6651-94)/-200... 1100 °C	
PT100 $\alpha = 0.003850$ (IEC 751)/-200... 850 °C	
PT100 $\alpha = 0.003916$ (JIS C 1604-81)/-200... 630 °C	
PT100 W100 = 1.3910 (GOST 6651-94)/-200... 1100 °C	
PT200 $\alpha = 0.003850$ (IEC 751)/-200... 850 °C	
PT500 $\alpha = 0.003850$ (IEC 751)/-200... 850 °C	
PT500 W100 = 1.3910 (GOST 6651-94)/-200... 900 °C	
PT1000 $\alpha = 0.003850$ (IEC 751)/-200... 266 °C	
PT98 $\alpha = 0.003923$ (SAMA RC-4-1966)/-200... 650 °C	
NI100 W100 = 1.617 (GOST 6651-94)/-60... 180 °C	
NI100 W100 = 1.617 (PN-83/M-53952)/-60... 180.5 °C	
CU50 W100 = 1.426 (GOST 6651-94)/-50... 200 °C	
CU50 W100 = 1.428 (GOST 6651-94)/-185... 200 °C	
CU100 W100 = 1.426 (GOST 6651-94)/-50... 200 °C	
CU100 W100 = 1.428 (GOST 6651-94)/-185... 200 °C	
CU100 W100 = 1.426 (PN-83/M-53952)/-50... 180.5 °C	
Mathematical operations to be set for CH1 and CH2 channels	
PV – first process variable mapped in the process current value of the 4...20 mA current loop.	
PV = CH1;	
PV = CH2;	
PV = CH1-CH2;	
PV = CH2-CH1;	
PV = (CH1 + CH2)/2;	
PV = (CH1 + CH2)/2 or CH1 if CH2 fails or CH2 if CH1 fails;	
PV = min (CH1, CH2);	
PV = max (CH1, CH2).	

9. OPERATION

9.1. Operating temperature

Product	Standard version	Exi version
LI-24L	-40...+85 °C (-40...+185 °F)	-40...+85 °C (-40...+185 °F)
LI-24G	-40...+85 °C (-40...+185 °F)	-40...+70 °C (-40...+158 °F)

9.2. Remote configuration of setpoints (HART 5)

The transmitter allows to read out and configuring the parameters via HART communication using 4...20 mA loop as a physical layer for FSK BELL 202 modulation.

9.2.1. Compatible devices

The following devices may be used to communicate with the transmitter:

- Aplisens S.A. HART/USB or HART/RS232 converter;
- PC computers equipped with HART modem (e.g. HART/USB converter by Aplisens S.A.) with Windows7 or Windows10 operating system with installed Raport 2 or LI-24 Configurator software by Aplisens S.A.;
- PC computers equipped with HART modem using software from other companies, accepting DDL and DTM libraries;
- smartphones with Android system, using a converter providing wireless communication (e.g. HART/USB converter by Aplisens S.A.) using Aplisens Mobile Configurator. The software is available on Google Play under the link:

<https://play.google.com/store/apps/details?id=com.aplisens.mobile.amc>

9.2.2. Compatible configuration software

- Raport 2 Aplisens or LI-24 Configurator under control of Windows7 or Windows10;
- Aplisens Mobile Configurator under control of the Android system;
- every software from other companies accepting DDL and DTM libraries.

9.2.3. Method of connecting communication devices

The method of connecting communication devices locally to the transmitter is described in section → [Connection of transmitters with the option of using local HART communication](#). For remote communication, the HART modem should be connected in parallel to the 4...20 mA line. The resistance between the power supply and the modem connection point must be greater than 240 Ω. It is also required to observe the guidelines on the minimum load resistance R_{L_MAX} described in section → [Resistance load in power supply line](#). When using measuring cards with a built-in HART master, it is necessary to observe the instructions provided by the card manufacturer.

10. MAINTENANCE

10.1. Periodic inspections

Periodic inspections shall be carried out in accordance with applicable standards. During the inspection, check the condition of electrical terminal connections (reliability of the connections) and the stability of transmitter mounting.

10.2. Non-periodic inspections

If the transmitter at the installation site has been exposed to mechanical damage, overvoltage or incorrect operation of the transmitter is detected, the device should be inspected.



If there is no signal in the transmission line or its value is improper, check the supply line, connection status on terminal blocks, connectors, etc. Check if the supply voltage and load resistance are correct.

10.3. Spare parts

Parts of the transmitter that may be worn or damaged and thus replaced:

- mounting kit (2x M4 mounting screw, 2x compression spring) for the LI-24G transmitter.



Other parts in case of ATEX types of transmitters may be replaced only by the manufacturer or an authorized representative.

10.4. Repair

Faulty or non-operational transmitter shall be provided to the manufacturer.

10.5. Returns

In the following cases, the transmitter should be returned directly to the manufacturer:

- need for repair;
- need for factory calibration;
- replacement of improperly selected/shipped transmitter.

11. SCRAPPING, DISPOSAL



Worn or damaged devices shall be scrapped in accordance with WEEE Directive (2012/19/EU) on waste electrical and electronic equipment or returned to the manufacturer.

12. HISTORY OF REVISIONS

Revision No.	Document revision	Description of changes
-	01.A.001/2020.07	First version of the document. Prepared by DBFD.
1	01.A.002/2020.10	Change of ID numbers and QR codes. Prepared by DBFD.
2	01.A.003/2021.08	Added point 8.3. Prepared by DBFD.