

Technical Datasheet



Performance Series Bourdon Operated Pressure Switch

Models: 231, 232, 233 & 234

Key Features

- Precision stainless steel mechanism for arduous atmospheres and high humidity.
- Set point adjustable over the whole range against calibrated scale with tamperproof adjuster.
- Weatherproof and Flameproof models ATEX and IECEx.
- Safety vented design as standard.
- NACE MR-01-75 compatibility.
- Hermetically sealed microswitch option.
- Models for fixed switching differential, adjustable differential and HI-LO operation.
- Ranges available up to 600 bar (8,500 psi).
Static Pressure up to 690 bar (10,000 psi).



Product applications

The 230 Performance Series is suitable for a wide range of applications in:

- Oil & Gas
- Chemical
- Petrochemical
- Refining
- Power
- Food Industry

The choice of models available ensures that the 230 Performance Series is suitable for use in:

- Corrosive atmospheres
- Resistant to chemical attack

Series Overview

- Designed in the mid-1970s and developed over subsequent years, the Performance Series switch range offers users the broadest range of options, the highest levels of set-point repeatability and the confidence of long term performance that a mature product such as this can prove.
- The model 231/232/233/234 Performance Series pressure switches utilise bourdon tube type sensor that offer a very linear response to pressure change. This sensor, coupled with a precision stainless steel mechanism designed to minimise friction in the moving parts, helps deliver the market leading performance customers have come to expect from the series.

How can we help you?

Delta Controls' offers fast, efficient and knowledgeable support when and where you need it. Please visit our web site at www.delta-controls.com to find your local support centre or call us on:

+44 (0) 1252 729140

Performance Series
Models: 231, 232, 233 & 234

How to order

Switches can be configured by selecting codes representing the desired features from the tables that follow. The chart below, describes how the model code is built up. For assistance in configuring a switch that best suits your needs, please contact your local sales office.

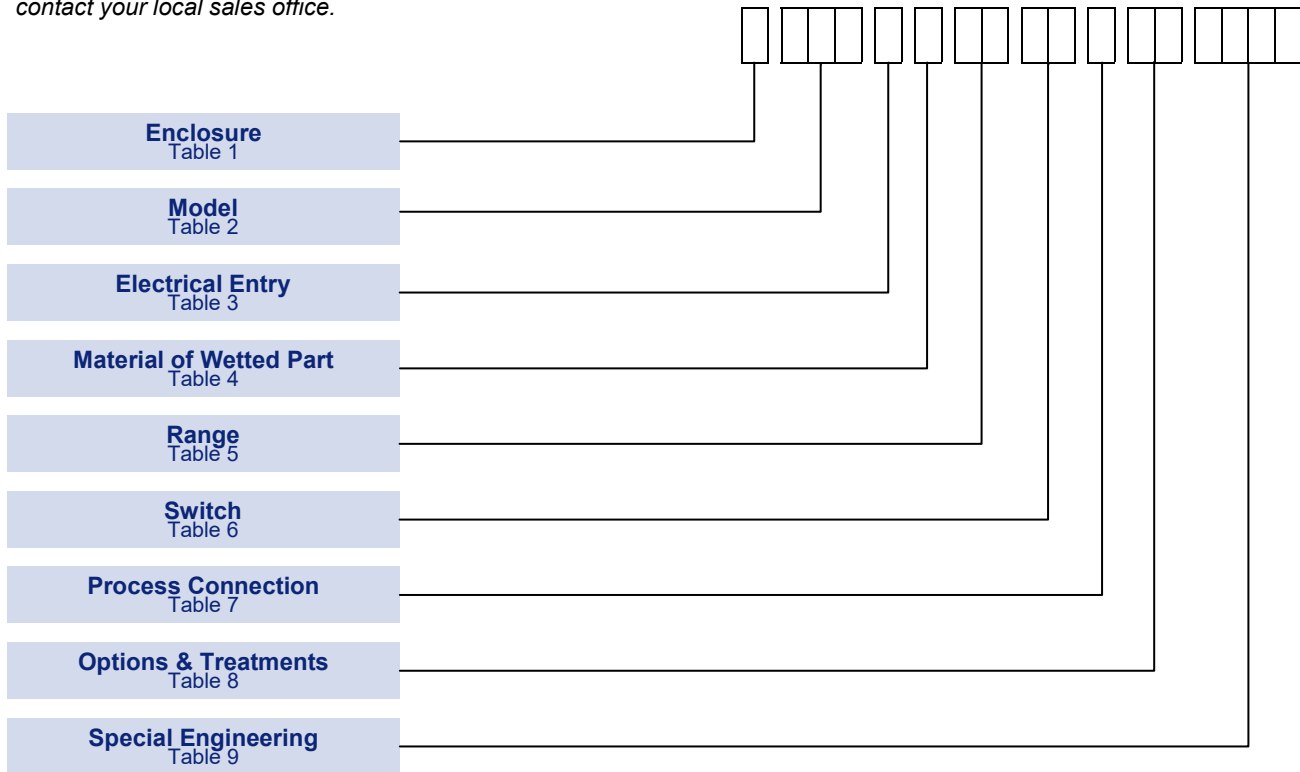

NOTE: Options shaded in the following tables are the most common options and are available on the quickest lead-times and at the lowest cost.

NOTE: Only the most common options are shown in this data sheet. Should you require a feature that is not shown, please contact your local sales office for further details.

Technical Specification

Performance Series
Models: 231, 232, 233 & 234

Accuracy:	Set point repeatability $\pm 1\%$ of span at 20°C / 68°F ambient. Scale accuracy $\pm 3\%$ of full scale.
Storage Temperature:	-25 to +60°C / -13 to +140°F
Ambient Temperature:	-25 to +60°C / -13 to +140°F Special build is also available for temperatures down to -60°C (-76°F)
Maximum Process Temperature:	Subject to appropriate installation practice, the component parts will withstand up to +120°C (+248°F). For higher temperatures refer to SPECIAL ENGINEERING.
Enclosure classification:	IP66 / NEMA 4X / Flameproof Ex d
Switch output:	SPDT or DPDT snap action microswitch (standard) Hermetically sealed (optional)
Electrical rating:	See Table 6
Process Connection:	Rc 1/4 (BSP), 1/4 NPT Internal, 1/2 NPT Internal & 1/2 NPT External
Approximate Weight:	Enclosures: “W & N” 3.1kg/6.8lb; “A & O” 3.9kg/8.6lb; “H” 4.6kg/10.2lb; “K” 9.4kg/20.7lb.

Electrical Entry

Adaptors are available for other popular thread sizes.

Enclosures 'W' and 'N'

Standard option code 1(22mm dia) is provided with a nylon 22/20 reducer and fibre washer suitable for a standard M20 cable gland and back nut. Option code 0 elbow adaptor is factory fitted. Adaptor kits may also be provided retrospectively to fit at site if required. Ask for details. See diagrams for dimensions.

'W' and 'N' SAFETY NOTE

If a metal cable gland is site fitted it must either be earthed locally or an earth/gland plate must be used to connect the body of the gland at the enclosure earthing point. Earth/gland plates can be provided either factory fitted or in kit form for site assembly. Ask for details.

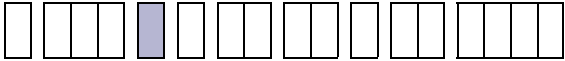
TABLE 3 

	Code
Enclosures W & N: Clearance for 20mm (3/4 in) outside dia conduit.	1
Enclosures H, K, A & O: M20 x 1.5 ISO thread (direct)	0
Enclosures H & K: M20 x 1.5 ISO thread, dual entry.	5
Enclosures H & K: 3/4-NPT INT.	3
Enclosures H & K: 3/4-NPT INT dual entry.	6
Enclosure W: M20 x 1.5 elbow adaptor.	0
Enclosure N: M20 x 1.5 straight adaptor (Approved).	0
Enclosures H & K: 1/2-NPT INT.	2

Material of Wetted Parts

Not all ranges are available with all materials. Refer to Table 5 for availability.

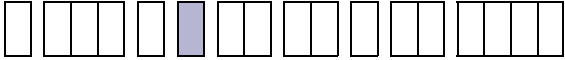
TABLE 4 

	Code
Bourdon tube and process connection of 316 stainless steel welded fabrication .	2
Nickel alloy (Monel) bourdon tube and connection*. For wetted parts required to conform with Sour Gas and Sour Crude applications as laid down in NACE standard MR-01-75*.	M

Setting Ranges

P_{max} = maximum working pressure

NOTE: Range codes shown are for bar/psi units only. Code will differ for other units.

For ranges and models requiring Monel wetted parts not shown in Table 5, ask for details.

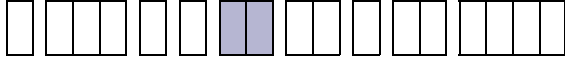
TABLE 5 

Range					
		231		232	
				233	
				234	
P_{max}	Range bar/ PSI	ST ST	Monel	ST ST	Code
125 1800	0 to 100 0 to 1500	✓	-	✓	U0 UB
184 2670	0 to 160 0 to 2000	✓	-	✓	U5 UF
287 4160	0 to 250 0 to 3500	✓	-	✓	V5 V2
460 6670	0 to 400 0 to 5800	✓	✓	✓	W6 W2
690 10,000	0 to 600 0 to 8500	✓	✓	✓	Y3 YB

Performance Series
Models: 231, 232, 233 & 234

Switching Options

TABLE 6

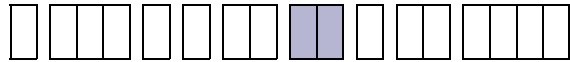

A much wider variety of switching options can be engineered to customers' special requirements for models 231 and 234 pressure switches, including heavy DC, manual latching, pneumatic output etc. On models 232 and 233, only the switching options specified can be supplied. Please consult our engineers for further information.

Model 231									
CSA RATING (RESISTIVE) § see note	IEC947-5-1 / EN 60947-5-1 RATING						Contact	Code	
	Designation & Utilisation Category	Rated operational current I_e (A) at rated operational voltage U_e	U_i	U_{imp}	VA Rating				
					Make	Break			
5 Amps @ 110/250V AC Light Duty for AC only	AC14 D300 DC13 R300	0.6/0.3A @ 120/240 V AC 0.22/0.1A @ 125/250V DC	250V	0.8kV	432 28	72 28	SPDT DPDT	00 01	
5 Amps @ 110/250V AC & 2 Amps @ 30V DC General purpose precision	AC14 D300 DC13 R300	0.6/0.3A @ 120/240 V AC 0.22/0.1A @ 125/250V DC	250V	0.8kV	432 28	72 28	SPDT DPDT	02 03	
1 Amp @ 125V AC & § 100mA @ 30V DC Gold Alloy contacts for low voltage switching	1A @ 125 VAC RESISTIVE (IEC 1058-1 / EN 61058-1)						SPDT DPDT	04 05	
§ 5 Amps @ 110/250V AC & 5 Amps @ 30V DC Environmentally sealed	AC14 D300 DC13 R300	0.6/0.3A @ 120/240 V AC 0.22/0.1A @ 125/250V DC	250V	0.5kV	432 28	72 28	SPDT* DPDT*	08 09	
§ 1 Amp @ 30V AC & 30V DC Environmentally sealed with gold contacts	AC14 E150	0.3A @ 120 V AC	125V	0.5kV	216	36	SPDT* DPDT*	0G 0H	
5 Amps @ 250V AC & 2 Amps @ 30V DC Hermetically sealed. Gold plated silver contacts	AC14 D300 DC13 R300	0.6/0.3A @ 120/240 V AC 0.22/0.1A @ 125/250V DC	250V	0.5kV	432 28	72 28	SPDT DPDT	H2 H3 [†] H6 [‡]	
† 2 Single pole, double throw, simultaneous falling under pressure ‡ 2 Single pole, double throw, simultaneous rising under pressure									
Model 232 (Cannot be supplied with enclosure Code N/O)									
5 Amps @ 110/250V AC Light Duty for AC only Adjustable	AC14 D300	0.6/0.3A @ 120/240 V AC	250V	0.8kV	432	72	SPDT	0C	
5 Amps @ 110/250V AC & 2 Amps @ 30 V DC Adjustable	AC14 D300 DC13 R300	0.6/0.3A @ 120/240 V AC 0.22/0.1A @ 125/250V DC	250V	0.8kV	432 28	72 28	SPDT	0D	
Model 233									
5 Amps @ 110/250V AC & 2 Amps @ 30V DC General purpose precision	AC14 D300 DC13 R300	0.6/0.3A @ 120/240 V AC 0.22/0.1A @ 125/250V DC	250V	0.8kV	432	72	SPDT	02	
Model 234									
5 Amps @ 110/250V AC Light Duty for AC only	AC14 D300 DC13 R300	0.6/0.3A @ 120/240 V AC 0.22/0.1A @ 125/250V DC	250V	0.8kV	432 28	72 28	SPDT	20	
5 Amps @ 110/250V AC & 2 Amps @ 30V DC General purpose precision	AC14 D300 DC13 R300	0.6/0.3A @ 120/240 V AC 0.22/0.1A @ 125/250V DC	250V	0.8kV	432 28	72 28	SPDT	22	
1 Amp @ 125V AC & § 100mA @ 30V DC Gold Alloy contacts for low voltage switching	1A @ 125 VAC RESISTIVE (IEC 1058-1/EN 61058-1)						SPDT	24	
§ 5 Amps @ 110/250V AC & 5 Amps @ 30V DC Environmentally sealed	AC14 D300 DC13 R300	0.6/0.3A @ 120/240 V AC 0.22/0.1A @ 125/250V DC	250V	0.5kV	432 28	72 28	SPDT*	28	
§ 1 Amp @ 30V AC & 30V DC Environmentally sealed with gold contacts	AC14 E150	0.3A @ 120 V AC	125V	0.5kV	216	36	SPDT*	2G	
5 Amps @ 250V AC & 2 Amps @ 30V DC Hermetically sealed. Gold plated silver contacts	AC14 D300 DC13 R300	0.6/0.3A @ 120/240 V AC 0.22/0.1A @ 125/250V DC	250V	0.5kV	432 28	72 28	SPDT	H4	

The electrical rating is dependent on the microswitch fitted to the instrument. The electrical ratings defined by each approval that the microswitch complies with and is shown on the product nameplate, ie CSA, or IEC. It should be noted that the instrument must be used within the electrical rating specified from the approval you require. This table lists the actual IEC ratings against the Designation & Utilisation Category marked on the nameplates. In the absence of any verification by CSA the microswitch § manufacturer's rating is stated in **italics and bold**. **If in doubt seek guidance from the factory.**

NOTE: For low energy circuits e.g. 30V and up to 100mA, we recommend using gold alloy contact switches.
 U_i = rated insulation voltage U_{imp} = rated impulse to withstand voltage across contacts.

*Suitable for use with Exn Enclosures (See Table 1)

Process Connection

Other thread specifications and sizes are available without using adaptors.

See DIMENSIONS.

Adaptors are available for applications where their use is permitted.

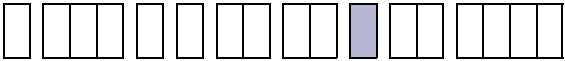
TABLE 7 

	Code
Rc 1/4 (1/4 BSP tr INT) to ISO 7/1	A
1/4—18 NPT INTERNAL	F
1/2—14 NPT INTERNAL	H
1/2—14 NPT EXTERNAL	J

Options & Treatments

Combinations available, apply for details.

TABLE 8 

	Code
Tropicalisation High humidity atmospheres	01
Marine and Offshore Saline atmosphere or salt spray	02
Ammonia Process (wetted) parts and construction suitable for atmospheric ammonia	03
Oxygen Service 2: Process (wetted) parts are cleaned for oxygen	04
Oxygen Service 3: Process and non-process parts are cleaned for use with oxygen	05
Stainless Steel Pipe Mounting Bracket Permits local 2" pipe work to be utilized for mounting the instrument	10
Tagging - Variety of tagging methods are available	APPLY FOR DETAILS
Applies when - no option is required and selection is made from special engineering	00

Special Engineering

Last 4 digits of model code only used when special engineering is required.

TABLE 9 

	Code
Please consult Delta sales engineering for special requirements	TBA

Performance Data

TABLE 10

Bar Units

TABLE 10A
MODEL 231
FIXED SWITCHING DIFFERENTIAL

MODEL 231

TABLE 10A

Code	Range	SPDT Options					DPDT Options				
		00	02	04	08 / 0G	H2	01	03	05	09 / 0H	H3 / H6
U0	0 to 100	1.2	2.5	1.2	2	3.6	2.4	2.4	2.4	3	3.6
U5	0 to 160	2	6	2	4	6	4	6	4	6	8
V5	0 to 250	3	9	3	10	9	6	12	6	15	12
W6	0 to 400	8	24	8	20	24	16	24	16	30	32
Y3	0 to 600	12	36	12	60	36	24	30	24	90	50

TABLE 10B
MODELS 232, 233
ADJUSTABLE SWITCHING DIFFERENTIAL

MODELS 232, 233

TABLE 10B

Code	Adjustable Range	MODEL 232				MODEL 233	
		SPDT Only				SPDT Options	
		0C		0D		02	
		From	To	From	To	From	To
U0	0 to 100	2	5	4	12	18	100
U5	0 to 160	3.2	8	6.4	19	35	160
V5	0 to 250	6	15	12	36	54	250
W6	0 to 400	12	30	24	72	100	400
Y3	0 to 600	18	45	36	108	150	600

Due to manufacturing tolerances the figures quoted in these tables are for guidance only and are typical for weatherproof models. Should the differential be critical for specific applications, our engineers should be consulted prior to ordering.

MODEL 234

TABLE 10C

Code	Range	Diff	20		Diff	22		Diff	24		Diff	28/2G		Diff	H4	
			Gap			Gap			Gap			Gap				
			Min	Max		Min	Max		Min	Max		Min	Max		Min	Max
U0	0 to 100	1.2	11	100	3.6	13	100	1.2	11	100	6	16	100	6	16	100
U5	0 to 160	2	25	160	8	28	160	2	25	160	10	33	160	10	33	160
V5	0 to 250	3	38	250	10.5	44	250	3	38	250	15	53	250	15	53	250
W6	0 to 400	8	80	400	24	96	400	8	80	400	40	120	400	40	120	400
Y3	0 to 600	12	100	600	36	124	600	12	100	600	60	160	600	60	160	600

PSI Units

TABLE 10D
MODEL 231
FIXED SWITCHING DIFFERENTIAL

MODEL 231

TABLE 10D

Code	Range	SPDT Options					DPDT Options				
		00	02	04	08 / 0G	H2	01	03	05	09 / 0H	H3 / H6
UB	0 to 1500	18	36	18	29	52	35	35	35	44	52
UF	0 to 2000	29	87	29	58	87	58	87	58	87	116
V2	0 to 3500	44	131	44	145	130	87	174	87	218	174
W2	0 to 6000	116	348	116	290	348	232	348	232	435	464
YB	0 to 8500	174	522	174	870	508	348	435	348	1305	725

TABLE 10E
MODELS 232, 233
ADJUSTABLE SWITCHING DIFFERENTIAL

MODELS 232, 233

TABLE 10E

Code	Adjustable Range	MODEL 232				MODEL 233	
		SPDT Only				SPDT Options	
		0C		0D		02	
		From	To	From	To	From	To
UB	0 to 1500	29	73	58	174	261	1500
UF	0 to 2000	47	116	93	276	500	2000
V2	0 to 3500	87	218	174	522	780	3500
W2	0 to 6000	174	435	328	1044	1450	6000
YB	0 to 8500	261	653	522	1566	2176	8500

Flameproof models may be up to 2 times higher depending on the range. Should the differential be critical for specific applications our engineers should be consulted prior to ordering

MODEL 234

TABLE 10F

Code	Range	Diff	20		Diff	22		Diff	24		Diff	28/2G		Diff	H4	
			Gap			Gap			Gap			Gap				
			Min	Max		Min	Max		Min	Max		Min	Max		Min	Max
UB	0 to 1500	18	160	1500	52	189	1500	18	160	1500	87	232	1500	87	232	1500
UF	0 to 2000	29	363	2000	116	406	2000	29	363	2000	145	480	2000	145	480	2000
V2	0 to 3500	44	551	3500	152	638	3500	44	551	3500	174	522	3500	174	522	3500
W2	0 to 6000	116	1160	6000	348	1393	6000	116	1160	6000	740	1740	6000	740	1740	6000
YB	0 to 8500	174	1450	8500	522	1798	8500	174	1450	8500	2320	2320	8500	2320	2320	8500

Performance Series
Models: 231, 232, 233 & 234

Electrical Connections

Terminal Block

Cable entry is to a non-pinching terminal block made of a non-hygroscopic thermosetting plastic, suitable for cables up to 2.5mm²/14AWG.

Earthing/Grounding

An earthing stud is provided inside all weatherproof enclosures, adjacent to the entry. External earthing is standard on flameproof versions. Safety note see Table 3.

Dielectric Strength

The electrical assembly is capable of withstanding *2kV between live parts and earth/ground and 500V between open contacts.

* 1.2kV for micro switch Codes H2, H3, H4 and H6. Refer to Table 6.

Electrical Entry

Standard options are listed in Table 3. Other threads can be accommodated by adaptors. Dual entry available, see Table 3.

Optional Extras

Chemical Seals

Chemical seals of our own or proprietary manufacture can be fitted when required.

Mounting Position/Location/Installation

Vertical as shown, IN DIMENSIONS, taking care to avoid siting in locations that transmit excessive shock or vibration. For further advice contact our engineers.

Pollution degree (EN60947-5-1)

All products are suitable for use in pollution degree 3. For extreme conditions where condensation may readily form, then sealed contacts should be used. See Table 6 Codes 08/09/28, 0G/0H/2G, H2/H3/H4/H6.

Electrical Isolation

These products are not suitable for electrical isolation. Always isolate circuit separately to carry out any electrical work.

Approvals

EUROPEAN DIRECTIVES



Low voltage Directive (LVD) 2014/35/EU.
Compliant to LVD

Pressure Equipment Directive (PED) 97/23/EC:

This product has a process connection size <=DN25 and is therefore categorised as sound engineering practice under Cat 3.3

ATEX APPROVALS



FLAMEPROOF:

Certificate No. BAS01ATEX2426X
EN 60079-0, EN 60079-1, EN 60079-31

For Zone 1 models (**Enclosure code H/K, see Table 1**)

	II 2 GD	Ex db IIC T4 (Tamb -60°C to +80°C) Gb
		Ex tb IIIC T135°C (Tamb -60°C to +80°C) Db IP66
	II 2 GD	Ex db IIC T6 (Tamb -60°C to +40°C) Gb
		Ex tb IIIC T85°C (Tamb -60°C to +40°C) Db IP66

GLOBAL CERTIFICATION



IECEx Certified

Ex db IIC T4 (Tamb -60°C to +80°C) Gb
Ex db IIC T6 (Tamb -60°C to +40°C) Gb

Certificate No. IECEx ITS 04.0006X
IEC 60079-0, EN 60079-1

Dimensions

All dimensions mm (inches)

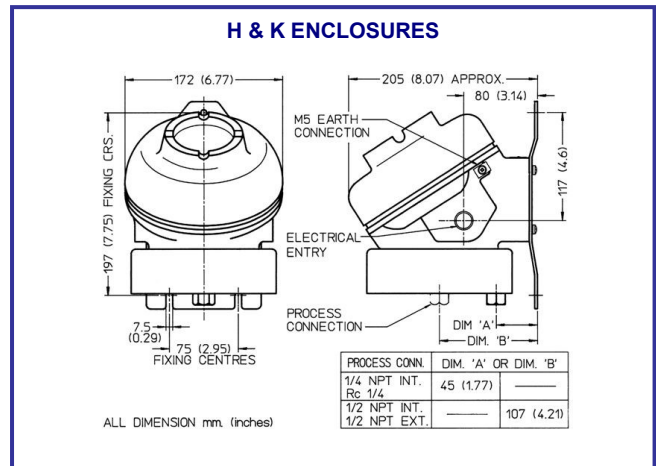
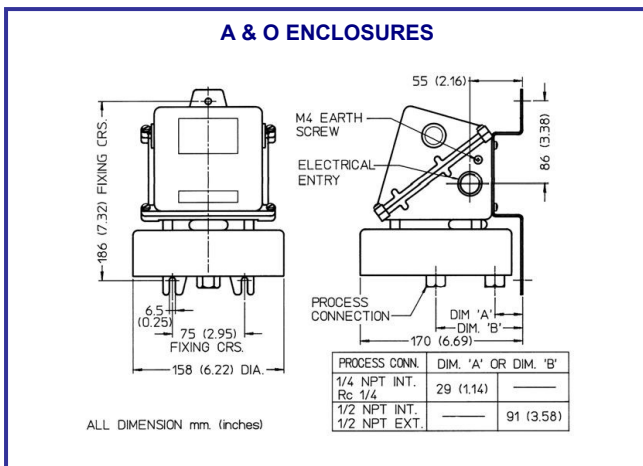
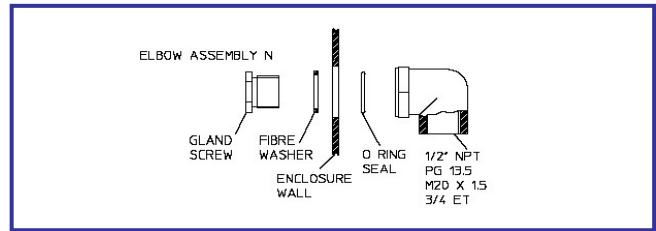
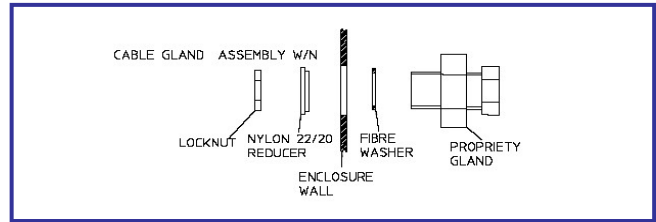
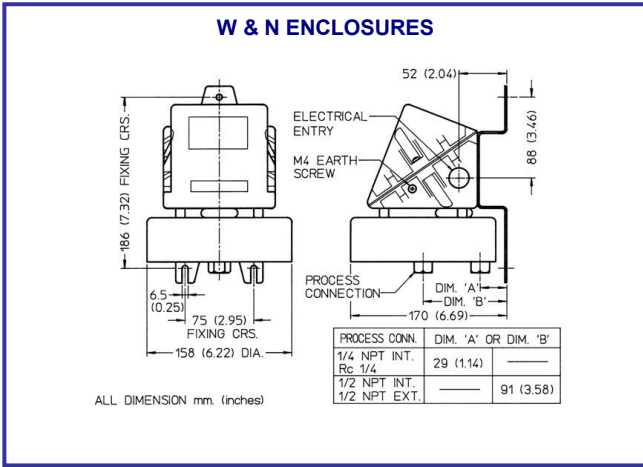

Performance Series
Models: 231, 232, 233 & 234

In the interest of development and improvement Delta Controls Ltd, reserves the right to amend, without notice, details contained in this publication. No legal liability will be accepted by Delta Controls Ltd for any errors, omissions or amendments.

Delta Controls Limited
Riverside Business Park, Dogflud Way, Farnham, Surrey GU9 7SS, UK.
T+44 (0)1252 729140 F+44 (0)1252 729168 E sales@delta-controls.com W www.delta-controls.com



ISO9001

FM00720